

ORDINANCE 25-17

AN ORDINANCE OF THE MAYOR AND CITY COUNCIL OF THE CITY OF MARICOPA, ARIZONA, ADOPTING THE DOCUMENT FILED WITH THE CITY CLERK AND ENTITLED “2025 AMENDMENTS TO TITLE 18: ZONING” BY REFERENCE TO AMEND CHAPTERS 18.40, 18.75, 18.80, 18.90, 18.120, 18.135, 18.140 AND 18.205 OF THE MARICOPA CITY CODE AND PROVIDING FOR SEVERABILITY AND THE EFFECTIVE DATE THEREOF.

WHEREAS, the City previously adopted Ordinances which established zoning rules and regulations to implement the city’s general plan and to protect and promote the public health, safety, peace, comfort, convenience, prosperity, and general welfare; and

WHEREAS, after review, City staff determined that the Maricopa City Code needed to be updated; and

WHEREAS, the Mayor and City Council of the City of Maricopa believe, after consultation with its staff, that amending of the City Code to update the City Zoning Code would be in the best interest of the City of Maricopa; and

WHEREAS, A.R.S. §9-802 allows a City to adopt a public record by Ordinance as a means to reduce publication costs while ensuring that the public gets fair notice and opportunity to review its operative provisions.

NOW, THEREFORE, BE IT ORDAINED BY THE MAYOR AND CITY COUNCIL OF THE CITY OF MARICOPA, ARIZONA, AS FOLLOWS:

SECTION 1. That certain document filed with the City Clerk and entitled “2025 Amendments to Title 18: Zoning” amending Chapters 18.40, 18.75, 18.80, 18.90, 18.120, 18.135, 18.140 and 18.205 of the Maricopa City Code as set forth in Exhibit A, attached hereto and incorporated herein by reference, is hereby declared a public record. One paper copy and one electronic copy of Exhibit A shall be maintained in compliance with A.R.S. § 44-7041 and available for public inspection during normal business hours in the Office of the City Clerk and shall be available on the City’s website at: www.maricopa-az.gov.

SECTION 2. Chapter 18.40: Commercial Districts, Chapter 18.75: Mixed Use-Heritage Overlay District, Chapter 18.80: General Site Regulations, Chapter 18.90: Landscaping, Chapter 18.120: Standards for Specific Uses, Chapter 18.135: Commissions, Committees, Boards and Officers, Chapter 18.140: Common Procedure and Chapter 18.205: List of Terms and Definitions of the Maricopa City Code are hereby amended as set forth in Exhibit A, and that the amendments depicted therein are hereby approved and adopted.

SECTION 3. To the extent of any conflict between other City Ordinances and this Ordinance, this Ordinance shall be deemed to be controlling; provided, however, that this Ordinance is not intended to amend or repeal any existing City Ordinance, Resolution or regulation except as expressly set forth herein.

SECTION 4. If any section, subsection, sentence, clause, phrase or portion of this Ordinance is for any reason held to be invalid or unconstitutional by the decision of any court of competent jurisdiction, such decision shall not affect the validity of the remaining portions thereof.

SECTION 5. This Ordinance shall become effective thirty (30) days from the date of adoption by the City Council for the City of Maricopa.

PASSED AND ADOPTED by the Mayor and Council of the City of Maricopa, Arizona, this 2nd day of December, 2025.

APPROVED:



Nancy Smith
Mayor

ATTEST:



Vanessa Bueras, MMC
City Clerk



APPROVED AS TO FORM:



Denis Fitzgibbons
City Attorney

Pursuant to A.R.S. 9-802(A), EXHIBIT A is on file at:

**Office of the City Clerk, City of Maricopa and
www.maricopa-az.gov.**

EXHIBIT A

Chapter 18.40

COMMERCIAL DISTRICTS

Sections:

- 18.40.010 Purpose.**
- 18.40.020 Land use regulations.**
- 18.40.030 Development standards.**
- 18.40.040 Review of plans.**
- 18.40.050 Alternative design.**

18.40.010 Purpose.

The purposes of the commercial districts are to:

- A. Designate adequate land for a full range of commercial uses and regional-serving retail services consistent with the general plan to maintain and strengthen the city's economic resources;
- B. Provide for the orderly, well-planned, and balanced growth of commercial areas;
- C. Plan for commercial development to expand the variety of goods and services to meet the needs of city residents and those living within Maricopa's market area;
- D. Establish design standards that improve the visual quality of development and create a unified, distinctive, and attractive character along commercial streets;
- E. Contribute to the pedestrian environment with standards that promote ground-floor visibility, orientation of buildings to the street, and pedestrian access across parking lots and between commercial centers and adjacent land uses;
- F. Ensure that new development is designed to minimize traffic and parking impacts and is appropriate to the physical characteristics of the area; and
- G. Address transitions and provide appropriate buffers between commercial and residential uses.

Additional purposes of each commercial district:

1. *NC Neighborhood Commercial.* This district is intended to provide areas for locally oriented retail and service uses that serve the surrounding residential trade area within one-half-mile to one-mile radius. Typical uses include, but are not limited to, retail stores, small grocery and drug stores, specialty food sales and services, restaurants and cafes, neighborhood dry cleaners, personal services (e.g., laundries, barbers, hair and nail salons, fitness studios), small gas stations, and convenience stores. Other compatible uses include small-scale medical and professional offices as well as public and semi-public uses. Large-format retail stores, greater than 40,000 gross square feet for a single user, and shopping centers are not appropriate in this district.
 2. *GC General Commercial.* This district is intended to provide retail and service-oriented businesses that serve a large surrounding residential trade area within a one- to five-mile radius. Examples of allowable uses include but are not limited to animal sales, care, and services; automobile servicing; building materials; storage facilities with active storefronts; equipment rental; wholesale businesses; and specialized retail and service uses not normally found in shopping centers.
 3. *GO General Office.* This district is intended to enhance employment opportunities and the overall economic vitality of Maricopa as well as to promote attractive development and ensure minimal impacts on surrounding development. It is intended for low- to medium-intensity office and medical center development located along thoroughfares, arterials, or collectors, or near existing/planned public transit stops. This district also allows supporting services such as banks, clinics, lodging, small-scale retail, service, or restaurant uses developed in conjunction with office use.
 4. *SC Shopping Center.* This district is intended to meet local and regional retail demand, such as large-scale retail, office, civic and entertainment uses, shopping malls with large footprints, “big-box” retail use, and other uses that are not appropriate in other areas because of higher volumes of vehicle traffic and potential impacts on other uses. Typical uses include but are not limited to grocery store and anchored tenant shopping centers with additional drug stores, fast food chains, smaller hardware and building supply stores, gas stations with convenience stores, and restaurants and cafes. Other compatible uses include medical and professional offices as well as public and semi-public uses. The focus of district development standards is to ensure that structures complement the surrounding development pattern.
-

18.40.020 Land use regulations.

Table 18.40.020 below prescribes the land use regulations for commercial districts. The regulations for each district are established by letter designations as follows:

“P” designates permitted uses.

“C” designates use classifications that are permitted after review and approval of a conditional use permit by the planning and zoning commission.

“(#)” numbers in parentheses refer to specific limitations listed at the end of the table.

“X” designates uses that are not permitted.

Table 18.40.020 Land Use Regulations – Commercial Districts

Uses	District				Additional Regulations
	NC	GC	SC	GO	
Residential					
Multiple-Unit Dwelling	P	X	X	X	
Public and Semi-Public					
Colleges and Trade Schools, Public and Private	X	P	X	P	
Community Assembly	X	P	X	X	MCC 18.120.070 , Community assembly
Cultural Facilities	P	P	P	X	
Day Care Facility	P	X(5)	X(5)	P	MCC 18.120.080 , Day care facilities
Educational Facility, Public and Private	P	X	X	X	

Uses	District				Additional Regulations
	NC	GC	SC	GO	
Emergency Shelters and Facilities	X	P	X	X	
Government Buildings	P(6) (7)	P(6) (7)	P(6) (7)	P(6) (7)	
Hospitals and Clinics					
Hospital	C(7)	C(7)	C(7)	C(7)	MCC 18.120.130 , Hospitals and clinics
Clinic	P	P	P	P	
Public Safety Facility	P(6)	P(6)	P(6)	X	
Social Service Facility	P	P	P	P	
Commercial					
Adult-Oriented Business	X	C	C(1)	X	MCC 18.120.020 , Adult-oriented businesses
Animal Sales, Care and Services					
Animal Sales and Grooming	P	P	P	X	MCC 18.80.030 , Animal keeping
Kennels	X	P	X	X	MCC 18.80.030 , Animal keeping
Small Animal Day Care	P	P	P	X	
Veterinary Services	X	P	P	P	

Uses	District				Additional Regulations
	NC	GC	SC	GO	
Automobile/Vehicles Sales and Services					
Automobile Rentals	X	P	P	P	
Automobile/Vehicle Repair, Minor	C	P	P	X	
Automobile/Vehicle Repair, Major	X	P	C	X	MCC 18.120.050 , Automobile/vehicle service and repair, major
Automobile/Vehicle Sales and Leasing	X	P	P	X	MCC 18.120.040 , Automobile/vehicle sales and leasing
Automobile/Vehicle Washing and Services	X	P	P	X	MCC 18.120.060 , Automobile/vehicle service stations and washing
Large Vehicle and Equipment Sales, Service, and Rental	X	P	X	X	
Service Station	C	P	P	X	MCC 18.120.060 , Automobile/vehicle service stations and washing
Banks and Financial Institutions					
Banks and Credit Unions	P	P	P	P	
Noninstitutional Banking	X	C	C	X	MCC 18.120.200 , Noninstitutional banking
Building Materials Sales and Service	X	P	P	X	

Uses	District				Additional Regulations
	NC	GC	SC	GO	
Business Services	P	P	P	P	
Commercial Entertainment and Recreation					
Banquet and Conference Centers	X	C	C	C	
Small-Scale Facility	P	P	P	X	
Large-Scale Facility	X	C(7)	C(7)	C(7)	
Theaters	X	P(7)	P(7)	X	MCC 18.120.030 , Alcoholic beverage sales
Club or Lodge	P	P	P	P	
Commercial Kitchen	X	P	P	X	
Eating and Drinking Establishments					
Bars and Lounges	P(2)	P	P	P	MCC 18.120.030 , Alcoholic beverage sales MCC 18.120.100 , Eating and drinking uses MCC 18.120.190 , Outdoor dining and seating
Restaurants, Full Service	P	P	P	P	MCC 18.120.030 , Alcoholic beverage sales MCC 18.120.100 Eating and drinking

Uses	District				Additional Regulations
	NC	GC	SC	GO	
					uses MCC <u>18.120.190</u> , Outdoor dining and seating
Restaurants, Limited Service (including Fast Food)	P	P	P	P	MCC <u>18.120.090</u> , Drive-in and drive-through facilities, including fast-food facilities MCC <u>18.120.100</u> , Eating and drinking uses MCC <u>18.120.190</u> , Outdoor dining and seating
Restaurant, Take-Out Only	P	P	P	P	MCC <u>18.120.100</u> , Eating and drinking uses MCC <u>18.120.190</u> , Outdoor dining and seating
Food and Beverage Sales					
Convenience Market	P	P	P	P	MCC <u>18.120.030</u> , Alcoholic beverages MCC <u>18.120.280</u> , Food and beverage sales
General Market	P(4)	P(7)	P(7)	X	
Liquor Store	C	C	C	X	
Specialty Food Sales and Facilities	P	P	P	P	
Funeral Parlors and Mortuaries	P	P	P	X	

Uses	District				Additional Regulations
	NC	GC	SC	GO	
Instructional Services	P	P	P	X	
Live/Work	P(1)	P	X	X	MCC 18.120.140 , Live/work units
Lodging					
Hotels and Motels	X	P(7)	P(7)	P(7)	
Maintenance and Repair Services	P(3)	P	P	X	
Qualifying Marijuana Uses					
Dispensary Facilities	X	C	X	X	MCC 18.120.160 , Medical marijuana facilities
Mobile Merchants	P	P	P	P	MCC 18.120.170 , Mobile merchants
Nurseries and Garden Centers	X	P	P	X	
Offices					
Business and Professional	P(1)	P(1)	P(1)	P	
Medical and Dental	P	P	P	P	
Walk-In Clientele	P	P	P	P	
Parking Facility, Public and Private	P(7)	P(7)	P(7)	P(7)	
Personal Services					

Uses	District				Additional Regulations
	NC	GC	SC	GO	
General Personal Services	P	P	P	P	MCC 18.120.210 , Personal services and restricted personal services
Restricted Personal Services	X	C	C	X	MCC 18.120.210 , Personal services and restricted personal services
Outdoor, Temporary, and Seasonal Sales	P	P	P	X	MCC 18.120.260 , Temporary uses
Off-Track Betting	X	C	C	X	MCC 18.120.180 , Off-track betting establishments
Retail Sales					
General Retail, Small-Scale	P	P(7)	P(7)	X	MCC 18.120.250 , Restricted retail uses
General Retail, Large-Scale	X	P	P	X	
Restricted Retail Uses	X	C	X	X	
Industrial					
Artist Studio and Production	P (3)	C	X	X	
Research and Development	X	X	X	C	
Storage and Warehouse					
Indoor Warehousing and Storage	X	P	X	P	

Uses	District				Additional Regulations
	NC	GC	SC	GO	
Personal Storage	X	P	P	X	
Transportation, Communication, Utility					
Bus/Rail Passenger Facilities	C	C	C	C	
Communication Facilities					
Antennas and Transmission Towers	Subject to existing regulations, including a conditional use permit if certain standards are not met or thresholds exceeded.				
Facilities within Buildings	P	P	P	P	
Recycling Facility					
Recycling Collection Facility	C	P	P	P	MCC 18.120.230 , Recycling facilities
Utilities					
Minor	P	P	P	P	
Accessory Uses	Subject to the same permitting requirements of the principal use unless additional review is established in MCC 18.120.010 , Accessory uses				

Uses	District				Additional Regulations
	NC	GC	SC	GO	
Temporary Uses	Require a temporary use permit, unless exempt; see MCC 18.120.260 , Temporary uses				
Nonconforming Uses	Chapter 18.100 MCC, Nonconforming Uses and Structures				

1 Upper floors only if available.

2 Wine and beer sales only.

3 Small scale, less than 1,500 square feet.

4 Less than 40,000 square feet.

5 Permitted as an accessory use. See MCC [18.120.010](#), Accessory uses.

6 Outdoor storage yards are not permitted.

7 Any single development, or combination of developments, totaling 50,000 square feet or more of gross floor area shall provide one (1) unique, pedestrian-oriented feature. Acceptable features may include, but are not limited to, fountains, sculptures, murals, or other generally recognized forms of public art.

18.40.030 Development standards.

Table 18.40.030, below, prescribes development regulations for commercial districts. The first five columns establish minimum requirements for permitted and conditional uses. Letters in parentheses in the “Additional Regulations” column refer to regulations following the schedule. The letter “Y” in the district column means that the additional regulation applies. The numbers in each illustration below refer to corresponding regulations in the “#” column in the associated table. Regulations applicable to multiple districts are in Division 4 of this code.

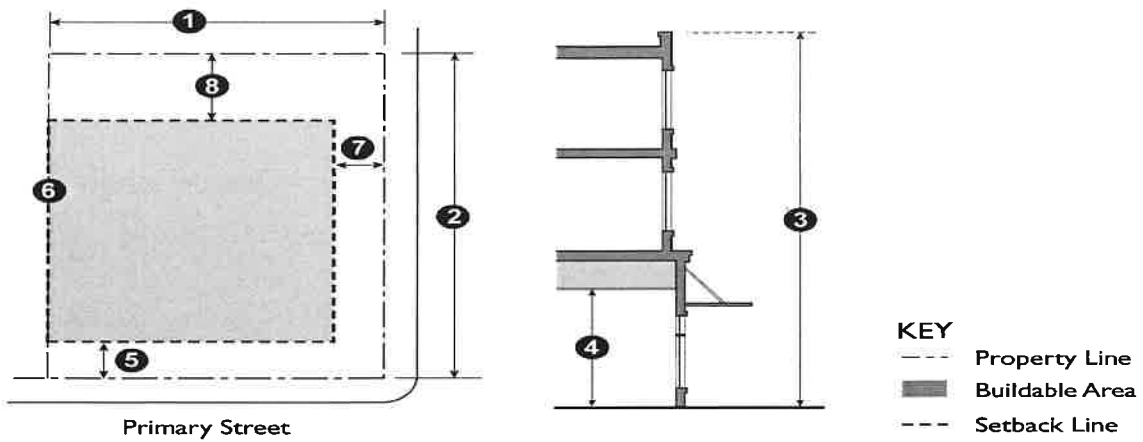

Table 18.40.030 Development Standards – Commercial Districts

	District				Additional Regulations	#
	NC	GC	SC	GO		
Lot and Density Standards						
Minimum Lot Area (s/f)	5,000	10,000	20,000	10,000		
Minimum Lot Width (ft.)	25	50	100	75		1
Minimum Lot Depth (ft.)	75	100	100	100		2
Maximum Density (units/net acre)	20	n/a	n/a	n/a		
Building Form and Location						
Maximum Building Height (ft.)	40	40	40	40		3
First Floor Ceiling Height (ft.)	12	n/a	12	12		4

	District				Additional Regulations	#
	NC	GC	SC	GO		
clear)						
Setbacks (ft.)						
Front	10	20	20	20	(A)	5
Interior Side	0	0	0	0		6
Street Side	10	20	20	20	(A)	7
Rear	20	30	40	30		8
Screening of Parking	Y	Y	Y	Y	(B)	
Other Standards						
Building Design	Y	Y	Y	Y	(C)	
Ground-Floor Transparency	Y	n/a	Y	Y	(D)	
Outdoor Living Area (s/f per unit)	100	n/a	n/a	n/a	(E)	
Pedestrian Access	Y	Y	Y	Y	(F)	
Private Storage Space	Y	n/a	n/a	n/a	(G)	
Transitions Adjacent to Residential Districts	Y	Y	Y	Y	(H)	
Transparency	Y	Y	Y	Y	(D)	

	District				Additional Regulations	#
	NC	GC	SC	GO		
Additional Standards						
Accessory Structures	MCC 18.80.020 , Accessory building or structures					
Exceptions to Height Limits	MCC 18.80.080 , Exceptions to height limits					
Fences and Walls	MCC 18.80.090 , Fences and freestanding walls					
Landscaping	Chapter 18.90 MCC, Landscaping					
Lighting	Chapter 18.95 MCC, Lighting					
Off-Street Parking and Loading	Chapter 18.105 MCC, On-Site Parking and Loading					
Outdoor Storage	MCC 18.80.100 , Outdoor storage					
Projections into Required Setbacks	MCC 18.80.040 , Building projections into yards					
Screening	MCC 18.80.110 , Screening					
Signs	Chapter 18.115 MCC, Signs					
Swimming Pools	MCC 18.80.120 , Swimming pools and spas					
Visibility at Driveways	MCC 18.80.150 , Visibility at intersections and driveways					

A. *Improvement of Street-Facing Setbacks.* Where a front or street-facing side setback is provided, it should be landscaped and/or hard-surfaced for use by pedestrians. If hard-surfaced, the setback area on each lot must be a plaza or gathering area and contain at least

two pedestrian amenities such as benches, drinking fountains, and/or other design elements (public art, planters, and kiosks).

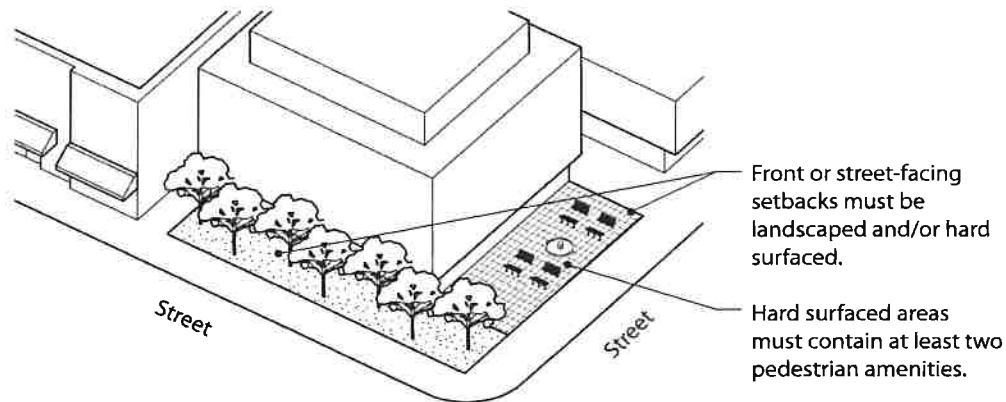

Figure 18.40.030.A. Street-Facing Setbacks

B. *Screening of Parking.* Any parking area located between a building and the street shall be screened with a wall or berm at least three feet and not to exceed three and one-half feet high. A screening wall shall be composed of brick, stone, stucco, or other quality durable material and shall include a decorative cap or top finish as well as edge detail at wall ends. A combination of these materials may be used, or may be combined such that no more than 40 percent of the screening shall be accomplished with densely planted landscaping.

C. *Building Design.* The exterior design of all buildings, including all facades, shall be coordinated with regard to color, materials, architectural form, and detailing to achieve design harmony, continuity and horizontal and vertical relief and interest. The design of all buildings shall be compatible with the character of the neighboring area.

D. *Ground-Floor Transparency.* Exterior walls facing any front or street-facing lot line should include windows, doors, or other openings for at least 50 percent of the building wall area located between three and seven feet above the elevation of the sidewalk. No wall may run in a continuous plane for more than 20 feet without an opening. Openings fulfilling this requirement should have transparent glazing and provide views into work areas, display areas, sales areas, lobbies, or similar active spaces, or into window displays that are at least three feet deep.

1. *Exception for Structured Parking Facilities.* Multi-level parking garages, where permitted, are not required to meet the ground-floor transparency requirement.
2. *Sites with Multiple Buildings.* On sites that contain multiple buildings, the building ground-floor transparency requirement does not need to be met along street-facing facades of buildings that are located behind other buildings and not visible from the adjacent public street.
3. *Reduction through Development Review Permit.* The building opacity requirement may be reduced or waived by the zoning administrator, if it is found that:
 - a. The proposed use has unique operational characteristics with which providing the required windows and openings is incompatible, such as in the case of a cinema or theater; and
 - b. Street-facing building walls will exhibit architectural relief and detail, or will be enhanced with landscaping in such a way as to create visual interest at the pedestrian level.

E. *Outdoor Living Areas.* In NC Districts, decks and balconies or common areas for outdoor living shall be provided for all residential dwelling units.

1. *Minimum Dimensions.* The minimum horizontal dimension for a deck or balcony is six feet and the minimum dimension for a common area for outdoor living, such as a roof deck, is 10 feet.
2. *Common Areas – Shared Open Space.* Common areas shall be accessible to residents, open to the sky, and not include any ground-level area required for front or corner side setbacks.
3. *Averaging Allowed.* The amount of outdoor living area provided for individual units may vary, based on unit size and location within a project, as long as the average area per unit meets the applicable standard.

F. *Pedestrian Access.* A system of pedestrian walkways shall connect all buildings on a site to each other, to on-site automobile and bicycle parking areas, to off-site sidewalks, and to any on-site open space areas or pedestrian amenities. Direct and convenient access shall be provided

to adjoining residential and commercial areas to the maximum extent feasible, while still providing for safety and security.

1. Walkways shall be a minimum of six feet wide, hard-surfaced, and paved with concrete, stone, tile, brick, or comparable material.
2. Where a required walkway crosses driveways, parking areas, or loading areas, it must be clearly identifiable through the use of a raised crosswalk, a different paving material, or similar method.
3. Where a required walkway is parallel and adjacent to an auto travel lane, it must be raised or separated from the auto travel lane by a raised curb, bollards, or other physical barrier.

G. *Private Storage Space for Residential Units in NC Districts.* Each unit shall have at least 200 cubic feet of enclosed, weather-proofed, and lockable private storage space with a minimum horizontal dimension of four feet.

H. *Transitional Standards.* Where a commercial district adjoins an interior lot line in a residential district, the following standards apply:

1. The maximum height is 30 feet within 40 feet of a residential district. From these points, the building height may be increased one foot for each additional foot of upper-story building setback to the maximum building height.
2. The minimum building setback shall be 25 feet from a residential district boundary.
3. Adjoining an RS District, a minimum 25-foot landscaped setback shall be provided, free from parking and other encroachments.

I. *Truck Docks, Loading, and Service Areas.* Truck docks, loading, and service areas are not permitted within 25 feet of the boundary of any residential district. In the NC, SC, and GO Districts, such loading and service areas must be located on the side or rear of buildings, and may not face a public street or a private street functioning as a public road

18.40.040 Review of plans.

Permit and review procedures shall follow the standards and approval criteria in Division 5, Administration and Permits.

18.40.050 Alternative design.

The zoning administrator may evaluate, and possibly accept or recommend to the decision-making body, alternative design requirements to meet the intent and the spirit of the code and other policy documents of the city of Maricopa.

Chapter 18.75**MIXED USE-HERITAGE OVERLAY DISTRICT**

Sections:

- 18.75.010 Purpose.**
- 18.75.020 Land use regulations.**
- 18.75.030 Development standards.**
- 18.75.040 Review of plans.**
- 18.75.050 Alternative design.**

18.75.010 Purpose.

- A. The purpose of the Mixed Use-Heritage Overlay District is to:
1. Promote pedestrian-oriented infill development, intensification, and reuse of land consistent with the general plan and the Heritage District Redevelopment Area Plan;
 2. Implement the Heritage District Design Guidelines to develop a strong identity as a mixed use urban core for the city which reflects the rich culture and historical character of Maricopa;
-

3. Encourage diverse and attractive redevelopment to support a mix of residential, pedestrian, and neighborhood-serving uses in order to achieve an active social environment within a revitalized streetscape while also respecting the existing character;
4. Encourage investment in adequate public facilities through quality redevelopment and improvements;
5. Offer additional housing opportunities for residents seeking to live and work in an urban environment; and
6. Ensure that new development and redevelopment are designed to minimize traffic, parking and impacts on surrounding residential neighborhoods, and create walkable environments.

B. More specifically, this overlay district is intended to allow for the transformation of the Heritage District into a vibrant, pedestrian-oriented, mixed use neighborhood, consistent with the Redevelopment Area Plan, the Heritage District Design Guidelines, and mixed use development standards. The adaptive reuse of existing buildings for residential and commercial uses is supported with a focus on active home based businesses, storefronts and, where viable, upper-floor residences and pedestrian- and transit-oriented development that encourages pedestrian activity and connectivity to adjacent areas. New construction will be designed to be compatible with the Heritage District Design Guidelines in terms of size, scale, materials, and details, and a broad range of residential and commercial uses is allowed. Standards will create high-quality building design, ensure compatibility in land use and building form, and support mixed commercial and residential uses. [Res. 21-09; Ord. 21-05 § 2; Res. 14-36 § 303.01; Ord. 14-12 § 1.]

18.75.020 Land use regulations.

Table 18.75.020 below prescribes the land use regulations for the MU-H Overlay District. The regulations are established by letter designations as follows:

“P” designates permitted uses.

“C” designates use classifications that are permitted after review and approval of a conditional use permit by the planning and zoning commission.

“(#)” numbers in parentheses refer to specific limitations listed at the end of the table.

“X” designates uses that are not permitted.

Table 18.75.020 Mixed Use-Heritage Overlay District Land Use Regulations

Use	MU-H	Additional Standards
Agricultural		
Animal and Crop Production		
Urban Agriculture	P	
Residential		
Single-Unit Dwelling	P(1)	
Multiple-Unit Dwelling	P(2)	
Senior and Long-term Care	C	
Day Care Facility		
Small	C	MCC 18.120.080 , Day care facilities
Large	C	
Residential and Group Care Home	p	MCC 18.120.240 , Residential and group care homes
Supportive Housing	C	MCC 18.120.270 , Supportive and transitional housing facilities
Transitional Housing	C	
Public and Semi-Public		

Use	MU-H	Additional Standards
Community Assembly	P	MCC <u>18.120.070</u> , Community assembly
Cultural Facilities	P	
Child Care Centers	P	
Government Buildings	P	
Hospitals and Clinics		
Clinic	P	MCC <u>18.120.130</u> , Hospitals and clinics
Hospital	P	MCC <u>18.120.130</u> , Hospitals and clinics
Parks and Recreation Facilities, Public	P	
Public Safety Facility	P	
Social Service Facility	P	
Commercial		
Animal Sales, Care and Services		
Animal Sales and Grooming	P	MCC <u>18.80.030</u> , Animal keeping
Small Animal Day Care	P	
Banks and Financial Institutions		
Banks and Credit Unions	P	
Noninstitutional Banking	C	MCC <u>18.120.200</u> , Noninstitutional

Use	MU-H	Additional Standards
		banking
Business Services	P	
Commercial Entertainment and Recreation		
Small-Scale Facility	P	
Theaters	C	
Club or Lodge	P	
Eating and Drinking Establishments		
Bars and Lounges	P	MCC 18.120.030 , Alcoholic beverage sales MCC 18.120.100 , Eating and drinking uses MCC 18.120.190 , Outdoor dining and seating
Restaurants, Full Service	P	MCC 18.120.030 , Alcoholic beverage sales MCC 18.120.100 , Eating and drinking uses MCC 18.120.190 , Outdoor dining and seating
Restaurants, Limited Service (including Fast Food)	P	MCC 18.120.030 , Alcoholic beverage sales

Use	MU-H	Additional Standards
		MCC 18.120.100 , Eating and drinking uses MCC 18.120.190 , Outdoor dining and seating
Restaurant, Take-Out Only	P	MCC 18.120.030 , Alcoholic beverage sales MCC 18.120.100 , Eating and drinking uses MCC 18.120.190 , Outdoor dining and seating
Food and Beverage Sales		
Convenience Market	P	MCC 18.120.030 , Alcoholic beverage sales
General Market	P(4)	
Liquor Store	C(3)	
Specialty Food Sales, Food Truck Courts, and Facilities	P	MCC 18.120.300 Food Truck Courts
Instructional Services	P(2)	
Live/Work Quarters	P(2)	MCC 18.120.140 , Live/work units
Lodging		
Hotels and Motels	P	

Use	MU-H	Additional Standards
Maintenance and Repair Services	P(3)	
Mobile Merchant	A	MCC <u>18.120.170</u> , Mobile merchant
Office		
Business and Professional	P	
Medical and Dental	P	
Walk-In Clientele	P	
Personal Services		
General Personal Services	P	MCC <u>18.120.210</u> , Personal services and restricted personal services
Restricted Personal Services	X	(A); MCC <u>18.120.250</u> , Restricted retail uses
Retail Services		
General Retail, Small-Scale	P	(A); MCC <u>18.120.250</u> , Restricted retail uses
General Retail, Large-Scale	X	
Industrial		
Artist Studio and Production	P	
Bus/Rail Passenger Facility	P	
Transportation, Communication, Utility		

Use	MU-H	Additional Standards
Communication Facilities		
Antennas and Transmission Towers	P	Chapter <u>18.130</u> MCC, Telecommunications Facilities
Facilities within Buildings	P	
Recycling Facility		
Recycling Collection Facility	P	MCC <u>18.120.230</u> , Recycling facilities
Utilities		
Minor	P	
Accessory Uses	Subject to the same permitting requirements of the principal use unless additional review is established in MCC <u>18.120.010</u> , Accessory uses. Home-based businesses also are subject to the additional requirements of subsection (C) of this section.	
Temporary Uses	Requires a temporary use permit, unless exempt; see MCC <u>18.120.260</u> , Temporary uses	
Nonconforming Uses	Chapter <u>18.100</u> MCC, Nonconforming Uses and Structures	

1 Preexisting lots only.

2 Nonresidential uses on ground floors only unless approved by the decision-making body.

3 Small scale, less than 1,000 square feet.

4 Less than 40,000 square feet.

18.75.030 Development standards.

Table 18.75.030, below, prescribes development regulations for the MU-H Overlay District. The first three columns establish minimum requirements for permitted and conditional uses. Letters in parentheses in the “Additional Standards” column refer to regulations following the schedule. The letter “Y” in the district column means that the additional standard applies. The numbers in each illustration below refer to corresponding regulations in the “#” column in the associated table. Regulations applicable to multiple districts are in Division 4 of this code.

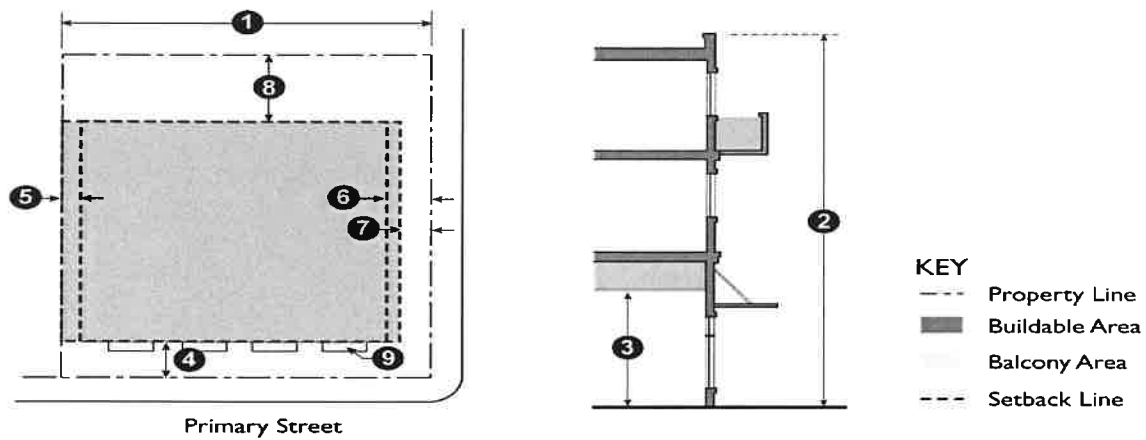

Table 18.75.030 Development Standards – Mixed Use-Heritage Overlay Districts

Use	District		#
	MU-H	Additional Standards	
Lot and Density Standards			
Minimum Lot Area (s/f)	7,000		
Minimum Lot Width (ft.)	50		1
Maximum Density	24		

Use	District	Additional Standards	#
	MU-H		
(units/net acre)			
Maximum Floor Area Ratio (FAR)	1.2	(A)	
Building Form and Location			
Maximum Building Height (ft.)	40		2
First Floor Ceiling Height, Nonresidential Uses (ft. clear)	12		3
Minimum Setbacks (ft.)			
Front	10		4
Interior Side, Residential Uses Only	5	(B)	5
Interior Side	0	(B)	6
Street Side	10	(C)	7
Rear	20	(B)	8
Maximum Front Setback (ft.)	20	(D)	
Location of Parking	Y	(E)	

Use	District	Additional Standards	#
	MU-H		
Other Standards			
Building Design	Y	(F)	
Outdoor Living Area (s/f per unit)	100	(G)	9
Outdoor Storage	N	(H)	
Sewer Service and Adequate Public Facility Participation Agreements	Y	(I)	
Transitions	Y	(J)	
Transparency for Ground-Floor Frontages, Nonresidential Uses	Y	(K)	
Additional Standards			
Accessory Structures	MCC <u>18.80.020</u> , Accessory building or structures		
Exceptions to Height Limits	MCC <u>18.80.080</u> , Exceptions to height limits		
Fences and Walls	MCC <u>18.80.090</u> , Fences and freestanding walls		
Landscaping	Chapter <u>18.90</u> MCC,		

Use	District	Additional Standards	#
	MU-H		
		Landscaping	
Lighting		Chapter <u>18.95</u> MCC, Lighting	
Off-Street Parking and Loading *		Chapter <u>18.105</u> MCC, On-Site Parking and Loading	
Outdoor Storage		MCC <u>18.80.100</u> , Outdoor storage	
Projections into Required Setbacks		MCC <u>18.80.040</u> , Building projections into yards	
Screening		MCC <u>18.80.110</u> , Screening	
Signs		Chapter <u>18.115</u> MCC, Signs	
Swimming Pools		MCC <u>18.80.120</u> , Swimming pools and spas	
Visibility at Driveways		MCC <u>18.80.150</u> , Visibility at intersections and driveways	

* For Ready-Set-Build homes, the requirements of Section 18.105.040 are not applicable*

A. *Increased FAR for Mixed Use Buildings.* The maximum allowable FAR may be increased by up to 25 percent for buildings that contain a mix of residential and nonresidential uses through the provision of one or more of the following elements beyond what is otherwise required, subject to conditional use permit approval:

1. Car-share or electric car facilities;

2. Additional public gathering space or contribution to a city parks fund supporting new or improved public parks within walking distance;
3. *Provision of Off-Site Improvements.* This may include off-site amenities and/or infrastructure (other than standard requirements and improvements) such as pedestrian or right-of-way improvements, public safety facilities, libraries, senior centers, community meeting rooms, or child care; and
4. Provision of green roofs, solar panels, and other green building measures.

B. *Required Side and Rear Yards for Residential Uses.* In order to provide light and air for residential units and additional separation for rooms that contain areas that require additional privacy considerations, the following minimum setbacks apply to any new building wall containing windows and facing an interior side or rear yard. When the site is adjacent to a residential use, the project must comply with whichever standard results in the greater setback. The required setbacks apply to that portion of the building wall containing and extending three feet on either side of any window.

1. For any wall containing living room or other primary room windows, a setback of at least 15 feet shall be provided.
2. For any wall containing sleeping room windows, a setback of at least 10 feet shall be provided.
3. For all other walls containing windows, a setback of at least five feet shall be provided.

C. *Reduced Street Side Setback.* Along local streets only, the street side setback may be reduced to five feet from the lot line if the setback area is completely landscaped.

D. *Maximum Building Setbacks.* The street-facing facades of buildings must be located no farther from street-facing property lines than the maximum setback distance specified in Table 18.75.030. The following additional provisions apply:

1. *Corner Properties.* Where a property fronts on two or more streets, the maximum setback shall be met according to the following provisions:
 - a. *Frontage on Two Primary Streets.* New buildings on sites with frontage on two streets may be constructed to the maximum setback line on both frontages.
-

- b. *Frontage on Three or More Streets.* Properties with frontage on three or more streets must build to the maximum setback lines of at least two of the streets.
2. *Sites with More than One Building.* Where there is more than one building on a site, the maximum setback standard must be met for at least 50 percent of the combined ground-level, street-facing facades of all buildings.
3. *Building Additions.* For any addition to a building that increases the width of a street-facing facade, 100 percent of the addition must be located on or within the maximum setback until the maximum setback standard for the entire building is met, or as otherwise recommended by the zoning administrator to meet the intent of this code.
4. *Exceptions to Building Placement Requirements.* The following exceptions to the build-to requirement are permitted:
- a. *Articulated Building Street Face.* Where a portion of the building is set back from the maximum setback to provide an entry or other feature creating variation in the facade, the total area of the space created by the setback must be less than the area of one square foot per linear foot of building frontage.
- b. *Outdoor Eating Areas.* Where an outdoor eating area will be installed on the street frontage, a portion of the building may be set back up to 12 feet farther than the maximum setback line, if at least 40 percent of the building facade is at the setback line.
- c. *Residential Uses.* For buildings or portions of buildings that are in residential use, open porches located at or within the maximum setback shall count toward meeting the requirement if such porches are at least 10 feet wide and six feet deep.
- E. *Location of Parking.* On-site parking areas shall be set back a minimum of 25 feet from streets. Exceptions may be granted for short-term customer parking and drop-off spaces and for preexisting uses.
- F. *Building Design and Signage.* In the MU-H Overlay District, the Heritage District Design Guidelines apply. In addition, the exterior design of all buildings, including all facades and all signage, shall be coordinated with regard to color, materials, architectural form, and detailing to achieve design harmony, continuity, and horizontal and vertical relief and interest.
-

G. *Outdoor Living Areas.* As part of the open space required by MCC Title 17, Subdivisions, private or common areas for outdoor living shall be provided for upper-level residential units. Outdoor living areas include balconies, decks, common open space, and rooftop open space.

1. *Minimum Dimensions.*

a. *Private Open Space.* Private open space located above ground level (e.g., balconies) shall have no horizontal dimension less than six feet.

b. *Common Open Space and Rooftop Open Space.* Common open spaces and rooftop open spaces with a minimum horizontal dimension of 20 feet shall count towards the open space calculation.

2. *Minimum Area Required – Private Open Space.*

a. One hundred square feet per unit.

b. The amount of outdoor living area provided for individual units may vary based on unit size and location within a project, as long as the average area per unit meets the applicable standard, or as acceptable by the zoning administrator to meet the intent of this title.

H. *Outdoor Storage.* Outdoor storage areas for nonresidential uses shall be only for retail and live/work uses and shall comply with the following requirements:

1. *Area.* Five percent of the gross floor area of the use or 200 square feet, whichever is less.

2. *Hours.* Outdoor storage during business hours only.

I. *Sewer Service and Adequate Public Facility Participation Agreements.* Sites within the MU-H Overlay District shall be permitted to develop or redevelop only after the owner agrees in writing to participate in paying its proportionate share of public facility improvement costs, including sanitary sewer services, in a manner acceptable to the city engineer.

1. The city engineer may require financial guarantees in the form of bonds or letters of credit or allow payment of fees in lieu to participate in paying the proportional cost of adequate public facilities to serve the site proposed for development.

2. The city engineer may approve interim solutions, such as on-site wastewater treatment facilities, in lieu of providing sanitary sewer service, should Pinal County public health department permit such interim solution.

3. All requests for improvements to existing residential properties within the MU-H Overlay District that do not include a commitment or assurance to participate in a proportionate share of the public facility improvements shall conform to the base zoning district development standards for setbacks, lot coverage and other requirements.

a. The hearing officer may approve a waiver to encroach into the required setback area or exceed the lot coverage established for the base zoning district for additions and improvements which: (i) conform to the Heritage District Design Guidelines; (ii) comply with current Pinal County health requirements for improving existing septic systems to accommodate the proposed improvements; (iii) meet outdoor screening and storage requirements of this code; and (iv) comply with the minimum development standards of the most comparable residential zone of this code based on existing lot size and dimensions. The GR District development standards shall be applied for all existing lots or parcels greater than 35,000 square feet.

J. *Transitional Standards.* Where this overlay district adjoins an interior lot line in a RS District, the following standards apply:

1. The maximum height within 30 feet of an RS District is 30 feet. From this point, the building height may be increased one foot for each additional foot of upper story building setback to the maximum building height.

2. The building setback from an RS District boundary shall be 25 feet for interior side and rear yards.

K. *Transparency on Ground Floor Frontages for Nonresidential Uses.* Windows, doors, or other openings shall be provided for at least 50 percent of the building wall area located between three and seven feet above the elevation of the sidewalk. No wall may run in a continuous plane for more than 20 feet without an opening. Openings fulfilling this requirement shall have transparent glazing and provide views into work areas, display areas, sales areas, lobbies, or similar active spaces, or into window displays that are at least three feet deep.

1. *Exception for Structured Parking Facilities.* Multi-level parking garages, where permitted, are not required to meet the ground-floor transparency requirement.

2. *Sites with Multiple Buildings.* On sites that contain multiple buildings, the building ground-floor transparency requirement does not need to be met along street-facing facades of buildings that are located behind other buildings and not visible from the adjacent public street.

3. *Reduction through Development Plan Review.* The transparency requirement may be reduced or waived by the zoning administrator upon finding that:

a. The proposed use has unique operational characteristics with which providing the required windows and openings is incompatible, such as in the case of a cinema or theater or communications facility; and

b. Street-facing building walls will exhibit architectural relief and detail, or will be enhanced with landscaping in such a way as to create visual interest at the pedestrian level.

L. *Truck Docks, Loading, and Service Areas.* Truck docks, loading, and service areas are not permitted within 25 feet of the boundary of any residential district. In addition, such loading and service areas must be located on the side or rear of buildings, and may not face a public street or a private street functioning as a public road.

M. *Pedestrian Access.* A system of pedestrian walkways shall connect all buildings on a site to each other, to on-site automobile and bicycle parking areas, to sidewalks, and to any on-site open space areas or pedestrian amenities. Direct and convenient access shall be provided to adjoining residential and commercial areas to the maximum extent feasible while still providing for safety and security.

1. Walkways shall be a minimum of six feet wide, hard-surfaced, and paved with concrete, stone, tile, brick, or comparable material.

2. Where a required walkway crosses driveways, parking areas, or loading areas, it must be clearly identifiable through the use of a raised crosswalk, a different paving material, or similar method.

3. Where a required walkway is parallel and adjacent to an auto travel lane, it must be raised or separated from the auto travel lane by a raised curb, bollards, or other physical barrier. [Res. 21-09; Ord. 21-05 § 2; Res. 14-36 § 303.03; Ord. 14-12 § 1.]

18.80.110 Screening.

A. *Screening of Mechanical Equipment.* All exterior mechanical equipment, whether on a roof, on the side of a structure, or located on the ground, shall be screened from public view. Exterior mechanical equipment to be screened includes, but is not limited to, heating, ventilation, air conditioning, refrigeration equipment, plumbing lines, ductwork, downspouts, transformers, smoke exhaust fans, water meters, backflow preventers, service entry section and similar utility devices. Screening shall be architecturally integrated into the main structure with regard to materials, color, shape, and size to appear as an integral part of the building or structure. Equipment shall be screened on all sides, and screening materials shall be opaque. When screening with plants, evergreen types of vegetation shall be planted and maintained. Plant material sizes and types shall be selected and installed so that at the time of building occupancy such plants effectively screen their respective equipment. The use of wood, expanded metal lath, and chain link for the purpose of screening is prohibited. The following additional screening standards apply:

1. *Roof-Mounted Equipment.* Whenever feasible, roof-mounted equipment screening shall be constructed as an encompassing monolithic unit or a series of architecturally similar screening units on large roofs, rather than as several individual screens (i.e., multiple equipment screens, or “hats,” surrounding individual elements shall not be permitted). The height of the screening element shall equal or exceed the height of the structure’s tallest piece of installed equipment.

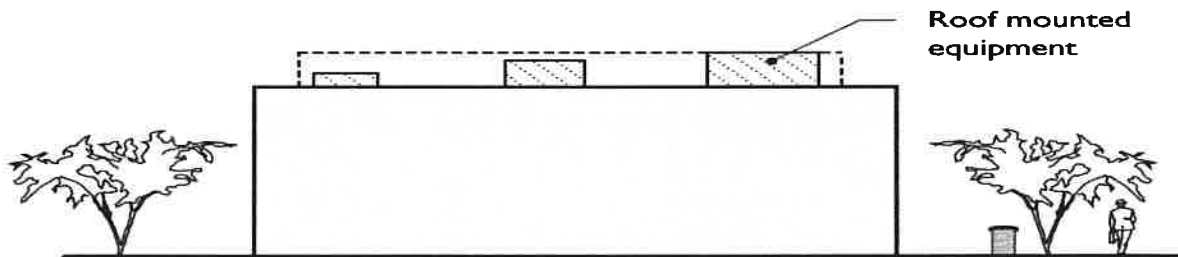

Roof mounted equipment screening shall be an encompassing monolithic unit and shall be the same height as the equipment.

Figure 18.80.110.A.1. Screening of Roof-Mounted Equipment

2. *Ground-Mounted Equipment.* Ground-mounted equipment including but not limited to water meters, backflow preventers, and transformers that faces a street or is not separated from the street by intervening building(s) shall be screened to a height of 12 inches above the equipment unless such screening conflicts with utility access, in which case reasonable accommodation shall be allowed. Screening devices shall consist of decorative walls and/or berms (3:1 maximum slope) with supplemental plant materials including trees, shrubs and ground covers. For screen walls that are three feet high or lower, vegetative materials may be substituted for 50 percent of the screening device. This requirement does not apply to equipment in the interior of a lot that is not visible from the street. Electrical substations, water tanks, sewer pump stations and similar utilities are required to be screened and secured with an eight-foot-high wall.

**Figure 18.80.110.A.2. Screening of Ground-Mounted Equipment**

3. *Exterior Wall Equipment.* Wall-mounted equipment, including but not limited to electrical meters, electrical distribution cabinets, service entry sections, downspouts, and valves and cabinets that face a street, public parking and is not recessed and/or separated from the street by intervening building(s) or walls or gates, shall be screened. Screening devices shall incorporate elements of the building design, e.g., shape, color, texture and material. For screen walls that are three feet in height or lower, vegetative materials may be substituted for 50 percent of the screening device. This requirement does not apply to fire related elements.

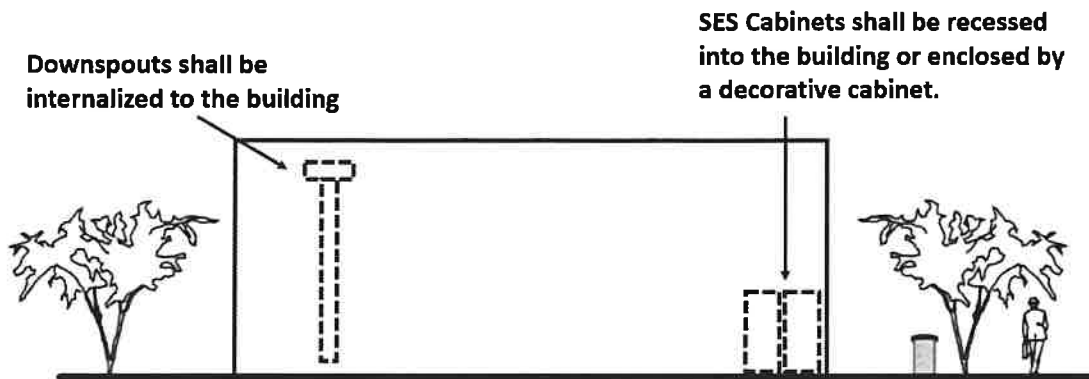

Figure 18.80.110.A.3. Screening of Exterior Wall-Mounted Equipment

4. *Upgrades to Existing Mechanical Equipment.* The hearing officer may waive or modify screening requirements for upgrades to existing mechanical equipment if reasonable accommodations are made to meet the intent of this code.

B. *Truck Docks, Loading, and Service Areas.* Truck docks, loading, delivery, and service bays shall be screened according to the standards of MCC [18.80.130](#) and Chapter [18.90](#) MCC.

C. *Roof Access Ladders and Fire Sprinkler Risers.* In all new construction, roof access ladders and fire sprinkler risers shall be located internally.

D. *Trash and Refuse Collection Areas.* Latching view-obscuring gates shall be provided to screen trash enclosure openings where visible from street and/or public parking areas. Gates' swings shall be clear of drive aisles and gates shall have a sign posted that reads, "KEEP GATES CLOSED AT ALL TIMES" (or equivalent). The trash enclosure shall match and complement the color scheme and architecture of the building.

E. *Parking Areas.* Parking areas and drive aisles shall be screened from street(s) with a combination of perimeter walls made of masonry (or similar material, such as gabion walls) and/or perimeter berms or landscape screening materials with supplemental shrubs and ground covers.

1. The screening device shall vary in height from a minimum of three feet and not to exceed three and one-half feet and shall be offset or staggered in plan by at least 24 inches at intervals of no more than 30 feet or include a mixture of live and solid walls.

2. The screening device shall vary in height from 12 to 18 inches when lawful display of automobiles, trucks, recreational vehicles, manufactured homes, boats, motorcycles, and utility trailers is adjacent to public streets.
3. Screen wall and/or berm height shall be measured from the finish grade of the parking lot.
4. A setback of at least five feet shall be provided between the screen wall and the edge of the parking area.
5. A setback of at least 10 feet shall be provided between the screen wall and the right-of-way, which may be reduced to five feet if the parking area frontage is 50 feet or less and there are no other conflicts, such as, but not limited to, public utility easements.
6. The hearing officer may approve alternatives to these screening standards if reasonable accommodations are made to meet the intent of this code.

F. *Common Lot Lines.* A screening wall shall be provided on the interior lot lines of any lot that contains any commercial use, industrial use, public or semi-public use (except cemetery or public park and recreation facility), or transportation, communication, and utilities use, and abuts a residential district or residential use. Such screening wall shall be provided at the time of new construction or expansion of buildings, or changes from one use classification to another nonresidential use classification.

1. *Location.* Screening walls shall follow the lot line of the lot to be screened, or shall be so arranged within the boundaries of the lot so as to substantially hide from adjoining lots the building, facility, or activity required to be screened.
 2. *Materials.* Industrial uses must provide a solid screening wall of stucco, decorative block, or concrete panel. Screening walls for other uses may be constructed of stucco, decorative block, concrete panel, wood or other substantially equivalent material. Chain link fencing does not fulfill the screening wall requirement.
 3. *Berms.* An earth berm may be used in combination with the above types of screening walls, but not more than two-thirds of the required height of such screening may be provided by the berm.
-

4. *Relationship to Fence and Wall Height Limits.* If the minimum required screening wall height exceeds the maximum permitted height of fences and freestanding walls for the zoning district, then a screening wall shall be provided that conforms with the maximum permitted fence height in the applicable portion of the property.

G. *Screening Along Residential District Boundaries.* A screening wall six feet in height is required wherever a site located in a commercial or mixed use district abuts a residential district. Openings in the wall are allowed for pedestrian access. The zoning administrator may require additional screening elements, up to eight feet in height, if necessary to screen commercial uses.

H. *Screening and Separation of Parking Areas.* Parking areas located between a building and street shall be screened with a screening wall or berm at least three feet and not to exceed three and one-half feet high. In addition, parking areas shall be separated from on-site buildings by a distance of at least 10 feet, which shall be landscaped and may also include a pedestrian walkway.

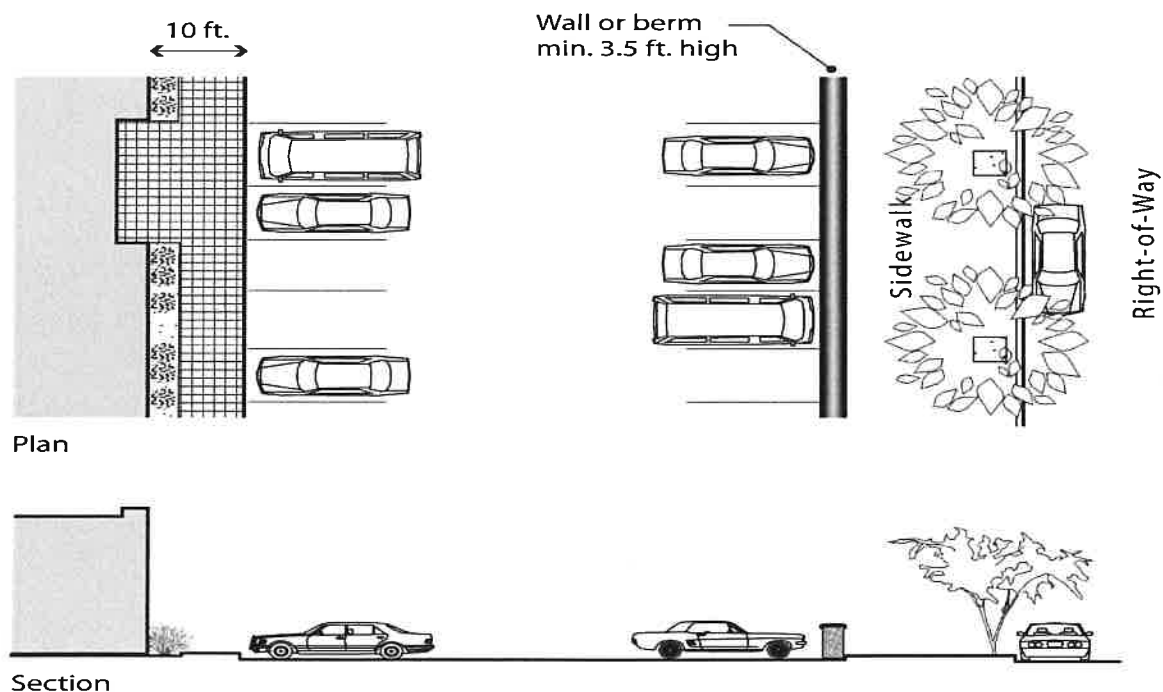

Figure 18.80.110.H. Screening and Separation of Parking Areas

I. *Screening and Location of Accessory Uses.* Outdoor accessory uses, such as, but not limited to, propane storage tanks, fuel storage and dispensing facilities not a part of a gas or service station, donation drop boxes and collection areas, are only permitted as an accessory use within commercial and industrial zoning districts and as an accessory to institutional and assembly uses. Such accessory uses shall not be located within the minimum front and street side building setback and shall meet all other applicable codes and ordinances. Accessory uses shall be shown on a site plan and provide screening and landscape in a manner to obscure views from adjacent roadways. [Res. 21-09; Ord. 21-05 § 2; Res. 14-36 § 401.11; Ord. 14-12 § 1.]

Chapter 18.90

LANDSCAPING

Sections:

- 18.90.010 Specific purposes.**
- 18.90.020 Applicability and exemptions.**
- 18.90.030 General requirements.**
- 18.90.040 Site landscaping on non-single-family lots.**
- 18.90.050 Parking lot landscaping.**
- 18.90.060 Recreation and Tot-lot design Requirements**

- 18.90.070 Alternative compliance.**

18.90.010 Specific purposes.

The specific purpose of this chapter is to establish standards for landscaping. The landscaping standards are intended to:

- A. Improve the appearance of the community by requiring aesthetically pleasing landscaping on public and private sites;
 - B. Soften the appearance of urban development;
 - C. Ensure appropriately designed and maintained landscaping elements that allow natural surveillance;
-

D. Generate and preserve community identity to reinforce a sense of place that is unique to various neighborhoods and districts throughout the city;

E. Encourage the use of drought-tolerant, native or adapted plant species and demonstrate appropriate design and maintenance techniques and discourage the use of nonnative invasive plants which require more water and have a negative impact on the city's natural environment; and

F. Provide environmental improvements, such as mitigating air and storm water pollution, providing shade, and reducing the effects of the urban heat island. [Res. 21-09; Ord. 21-05 § 2; Res. 14-36 § 404.01; Ord. 14-12 § 1.]

18.90.020 Applicability and exemptions.

A. *Applicability.* The regulations of this chapter shall apply to:

1. *Proposed Developments.* All buildings and uses of land, except active agricultural buildings located further than 100 feet from public rights-of-way.
2. *Existing Properties.* After the effective date of this code, for any proposed change to the primary exterior features of a building, such as alterations to entranceways, porches, driveways, and front yards, or exterior additions that project into the front yard, an increase in parking, or a change in use or building occupancy designation, the standards of this chapter apply.

B. *Exempt Projects.* The requirements of this chapter do not apply to:

1. Interior or upper-story additions to existing nonresidential or residential construction that add less than 20 percent to the existing floor area;
 2. The establishment of an accessory use on the same lot as an existing primary use, such as the installation of an accessory office space, with no expansion of floor area or outdoor area occupied; and
 3. A change in occupancy of a building that does not involve a change in the use type (e.g., the use classification). [Res. 21-09; Ord. 21-05 § 2; Res. 14-36 § 404.02; Ord. 14-12 § 1.]
-

18.90.030 General requirements.

A. *Landscaped Areas.* Required landscaped areas shall be maintained free from encroachment by any use, structure, vehicle, or feature not a part of the landscaping design, except for the fire hydrants and related fire protection devices, mailbox clusters, pedestals, poles, cabinets, utility-housing boxes, or other permanent fixtures as approved for emergency or service access.

1. Where turf abuts decomposed granite or similar inorganic landscape material, a hardscape edging material such as brick or concrete curb/mowstrip shall be provided.
2. Where vehicular cross-access is provided between adjoining properties that are not part of group commercial, office, or industrial development, a 15-foot-wide perimeter landscape yard except where drive aisle occurs shall be provided.

B. *Tree Size.* Required trees shall meet the growth dimensions specified in the Arizona Nursery Association "Recommended Tree Specification," latest edition, a copy of which will be maintained on file by the planning division and available upon request. The zoning administrator may approve deviations from these minimum specifications based on availability, if a deviation is requested prior to installation.

C. *Shrubs.* Required shrubs shall have a minimum mature growth height of 18 inches. At least 50 percent of required shrubs shall be a minimum of five gallons in size upon installation, but in no case shall any shrub be less than one-gallon size.

D. *Ground Cover.* Required ground cover may be of two types:

1. Vegetative ground cover consisting of living plant materials characterized by horizontal as well as vertical growth, generally not exceeding 18 inches in height.
 2. Inert ground cover consisting of gravel, decomposed granite, crushed rock, desert tree mulch, or other approved materials. The use of "desert cobble" that looks like the desert floor, consisting of natural desert covers and seed mix, is encouraged. Minimum depth of inert material shall be two and one-half inches.
-

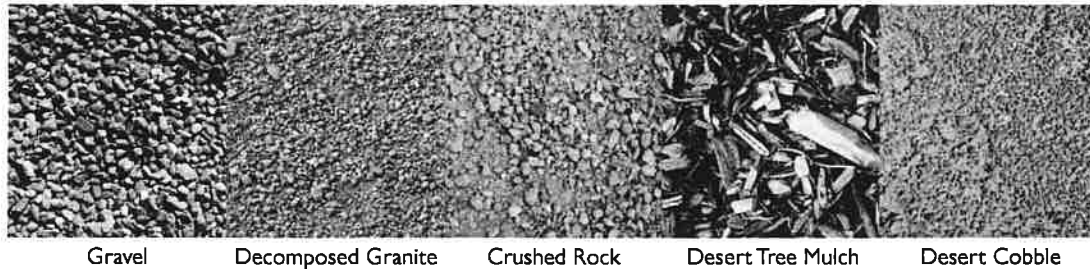

Figure 18.90.030.D. Ground Cover Types

E. *Irrigation Systems.* Required irrigation systems shall be underground automatic watering systems, unless the lot is served by functioning flood irrigation. Irrigation and plantings within three feet of public utilities, such as but not limited to electrical transformers, light poles and fixtures, and communication services, shall be limited to drip systems so as to not overspray to cause undue corrosion to utility structures.

F. *Paving and Hardscape Materials.* Paving and ground treatment shall be an integral part of site and landscape design.

G. *Minimum Open Space Required.* The following indicates the minimum required open space by zoning district:

1. Any parking area landscaping that exceeds the minimum requirements of the code shall be counted as open space if determined by the zoning administrator that the landscape area enhances the general area proposed.
2. Open space does not include parking areas except parking lots for trailheads and/or for the neighborhood parks (not parking lots required for other uses).
3. Bicycle trails (not bike lanes within the pavement section), pedestrian trails, equestrian tracts, and trailheads may also be calculated as open space.
4. Landscape buffers and landscaped medians shall be a minimum of 10 to 15 feet in width in order to be calculated as part of the required open space.

5. Open space does not include retention and/or detention basins that are concrete lined or nonlandscaped, vacant lots, or undeveloped lots.
6. Residential zoning districts shall have a minimum of 60 percent of the required open space for any development and should be developed as “useable” open space with the recreational amenities needed to support the new neighborhood demand incorporated into that open space.
7. Not more than 50 percent of the required open space shall be attributed to golf course use or ancillary golf uses.

H. *Maintenance.*

1. Individual property owners and/or homeowner’s associations shall properly maintain all landscape materials and landscape areas, including that within the public rights-of-way adjacent to the development, in accordance with the approved landscape plan, except in and along public rights-of-way and easements where the city of Maricopa has agreed to provide maintenance.
2. Replacement of dead trees and required landscaping shall be by the homeowner’s association or the individual property owner and shall be completed within three months from the date that the association or property owner is notified by the city.

Table 1 Open Space Requirements by Zoning Districts

Zoning District	Required Percentage of Open Space
Rural Districts	0% (1 – 49 lots; min. lot size 54,000 sq. ft.)
	2% (50+ lots; min. lot size 54,000 sq. ft.)
	10% (1 – 49 lots; min. lot size 20,000 sq. ft.)
	12% (50+ lots; min. lot size 20,000 sq. ft.)
Residential Districts	15% (1 – 99 lots; min. lot size 12,000 sq. ft.)
	17% (100+ lots; min. lot size 12,000 sq. ft.)

Zoning District	Required Percentage of Open Space
	20% (1 – 99 lots; min. lot size 7,000 sq. ft.) 22% (100+ lots; min. lot size 7,000 sq. ft.)
Mixed Use Districts	15%
Commercial Districts	10% (20 acres or less in size) 15% (greater than 20 acres in size)
Industrial Districts	10% (100 acres or less in size) 15% (greater than 100 acres in size)
Public Institutional Districts	10% (20 acres or less in size) 15% (greater than 20 acres in size)

[Ord. 24-04 § 2; Res. 21-09; Ord. 21-05 § 2; Res. 14-36 § 404.03; Ord. 14-12 § 1.]

18.90.040 Site landscaping on non-single-family lots.

A. Landscaping in Visible Yards.

1. *Standards.* Off-site street landscaping and on-site landscape buffer setback standards must comply with MCC [17.30.050](#). Street-facing yards, parking areas, and on-site landscaping shall comply with this code.

2. *Allowable Uses.* Yards that are visible from public streets and not used for parking lanes, or pedestrian walkways or allowable outdoor facilities shall be exclusively maintained as landscaped areas with plant materials and may include monument signs, parking screen walls, and retention basins as well as utility boxes and related equipment.

3. *Exceptions.* Outdoor seating for restaurants and cafes may encroach:

- a. In NC Districts, up to 50 percent of the width of the required landscape area; and
- b. In mixed use districts, the entire width of the required landscape area. The city encourages the use of tree wells and planters to help define outdoor seating areas and to enhance urban spaces.
4. *Numbers of Plants.* Except as otherwise required by the subdivision regulations, the required on-site plantings for multiple-family, mixed use, commercial, and institutional developments shall include a minimum of one tree and six shrubs per 650 square feet of landscaped area, with 40 percent ground cover. Industrial developments shall provide one tree and six shrubs per 1,000 square feet of landscaped area, with 25 percent ground cover. Where conflict occurs between the provisions of this code and MCC Title 17, Subdivisions, the more restrictive provision shall apply.
5. *Minimum Size.* In addition to minimum landscaping required in MCC 17.30.050, minimum size of plant materials shall be as follows:
- a. *Trees.*
- i. A minimum of 50 percent of the total required trees shall be 24-inch box trees.
- ii. No trees shall be smaller than 15-gallon size.
- b. *Shrubs.*
- i. A minimum of 50 percent of the total required shrubs shall be five-gallon size or larger.
- ii. No shrubs shall be less than one-gallon size.
- c. *Substitutions.* Substitutions for the above requirements may be made according to the following table:

Table 18.90.040.A.5.C Tree Substitutions

Tree to be placed on site	15-gallon tree equivalent	24-inch box tree equivalent
24-inch box tree	2 trees	-

Tree to be placed on site	15-gallon tree equivalent	24-inch box tree equivalent
36-inch box tree	3 trees	2 trees
48-inch box tree	4 trees	3 trees
60-inch or larger box tree	–	4 trees

6. *Ground Cover.* All landscape areas shall be covered with materials such as three-quarters inch Mountain Vista Brown landscape rock or similar material in combination with supplemental shrubs and ground covers, accents, flowers, and vines.

7. *Retention Basins.*

- a. Retention basins may not occupy more than 50 percent of the minimum required front yard and street side yard setback landscape areas.
- b. Basins along street frontages shall be incorporated into the landscape plan and designed to appear natural or integrated with the site plan and architecture of the site.
- c. Retention basins shall be constructed in accordance with plans approved by the city engineer and shall conform to grading and landscape plans approved by the city of Maricopa.

B. *Adjacent Lot Lines.*

1. *Buffer Zones Adjacent to Residential Zoning Districts and Open Space.*

- a. *Requirement.* Properties located adjacent to residential districts, community trail systems, and open space areas shall have a landscaped buffered area with a minimum width of 25 feet for commercial and mixed use districts, and 40 feet for industrial districts. In no case shall it exceed a 3:1 slope. At a minimum, buffer areas shall contain a minimum of one tree and two shrubs every 25 feet, or portion thereof, to provide visual screening between uses in addition to the minimum required landscaping on site.
- b. *Ground Treatment.* The buffer zone except for pedestrian walkways shall be covered with materials such as decomposed granite, desert varnish or cobble, desert tree

mulch, or turf, in combination with supplemental shrubs and ground covers, accents, flowers, and vines.

c. *Areas Visible from Rows, Public Parking or Drive Aisles.* Landscape material placement shall be designed to concentrate plantings in areas of high visibility to screen parking, loading, and trash enclosures from adjacent rights-of-way, properties, and pedestrian areas.

C. *Landscaping of Interior Setbacks.* Where a lot located in a commercial or mixed use district is adjacent to a residential district, at least 25 feet of the depth of such setbacks must be landscaped, and remain free from parking, driveways, and encroachment by any structures that are not part of the landscaping design. For properties that are adjacent to nonresidential districts, at least 40 feet of the depth of interior setbacks must be landscaped, unless specified elsewhere in this code.

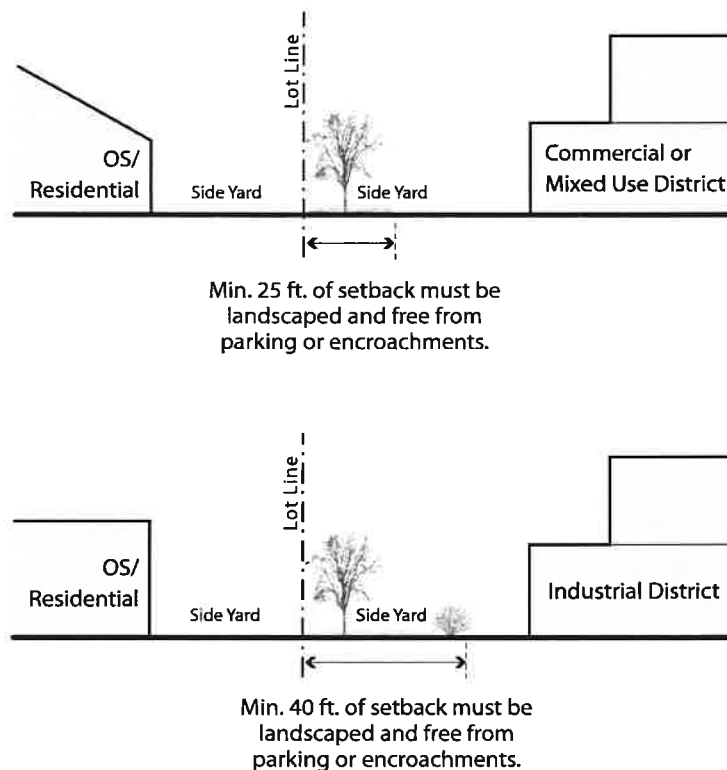

Figure 18.90.040.C. Landscaping of Interior Setbacks

[Res. 22-12; Ord. 22-03 § 2; Res. 21-09; Ord. 21-05 § 2; Res. 14-36 § 404.04; Ord. 14-12 § 1.]

18.90.050 Parking lot landscaping.

A. *Applicability.* The interior parking lot landscaping standards of this section apply to all off-street parking lots containing 10 or more parking spaces with exceptions where shade structures are provided for parking spaces. They do not apply to readapted residential properties in the MU-H Overlay District or vehicle/equipment storage lots or vehicle and equipment sales lots.

B. *Landscape Islands.*

1. Parking lot landscape islands shall be installed at each end of a row of stalls and in between for a maximum of eight contiguous parking spaces.
2. Landscape islands shall be a minimum of eight feet wide and 15 feet in length for single-row and 30 feet in length for double-row parking. All measurements are to face of curb. Projects may be eligible for sustainable development bonus incentives if increased landscaping is provided.
3. Radius curbing shall be provided along drive aisles with a minimum four-foot radius.
4. For rows of more than 16 parking spaces, landscape islands shall be staggered.

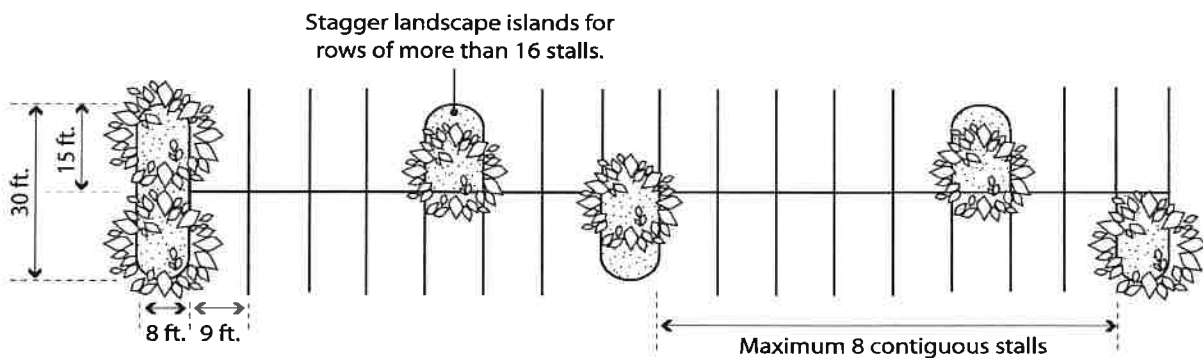

Figure 18.90.050.B.4. Landscape Islands

5. The maximum length of a covered parking canopy shall be 15 contiguous parking spaces. Landscape islands within a row of parking may be eliminated when a conflict with

the covered parking canopy occurs. However, landscape islands must be installed at the end of all parking rows.

6. When parking canopies are adjacent to each other in a single row, the total length of each canopy shall not exceed 15 parking stalls and the adjoining canopies shall be separated by at least a 24-foot-wide landscape island as depicted in the following illustration:

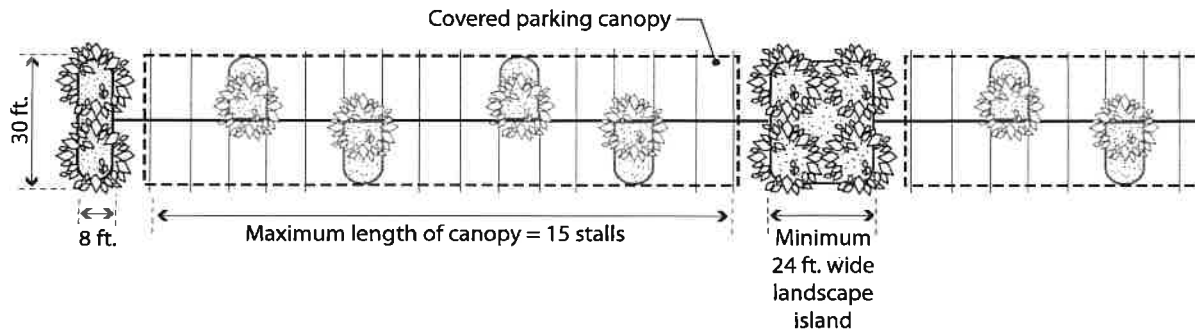

Figure 18.90.050.B.6. Adjacent Canopies

7. For parking lots containing more than 200 spaces, one eight-foot-by-15-foot staggered landscape island may be replaced with two landscape islands of at least 25 square feet clear landscape area each. Each landscape island/planter shall contain at least one tree and three shrubs. These landscape islands/planters may be designed in any combination of shape and size provided the minimum clear landscape area dimension is five feet.

8. To minimize conflict, a landscape island shall not be located adjacent to an ADA parking stall.

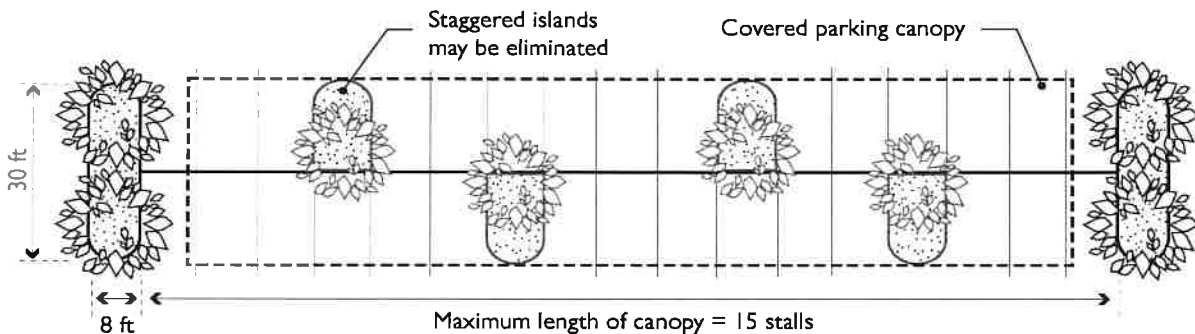

Figure 18.90.050.B.7. Covered Canopies

C. *Medians*. Where divider medians occur adjacent to head-in parking, vehicle overhang shall be as follows:

1. *Single-Row Parking*. A minimum seven-foot (or nine feet if a two-foot overhang is provided) landscape area is required. The required median width does not include a sidewalk.

Figure 18.90.050.C.1. Single-Row Parking

2. *Double-Row Parking*. A minimum eight-foot landscape area (or 11 feet if a two-foot overhang is provided on both sides of median) measured from face of curb to face of curb is required where the median width does not include a sidewalk.

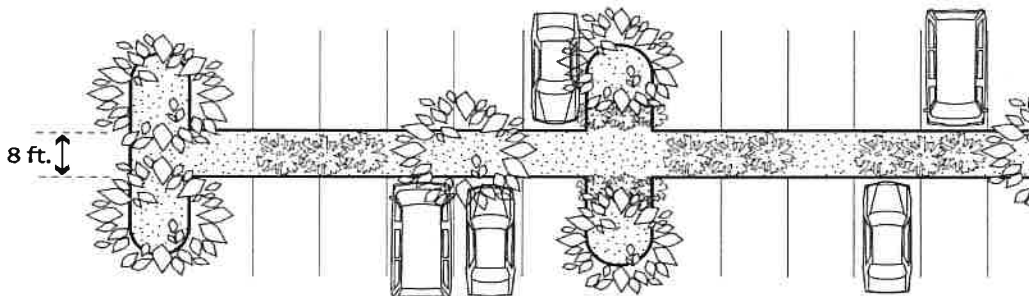

Figure 18.90.050.C.2. Double-Row Parking

3. *Medians with Sidewalks*. When a sidewalk is located within a median, shade trees should be placed so that at least 25 percent of the sidewalk is shaded at noon. The sidewalk shall be no less than four feet in width.

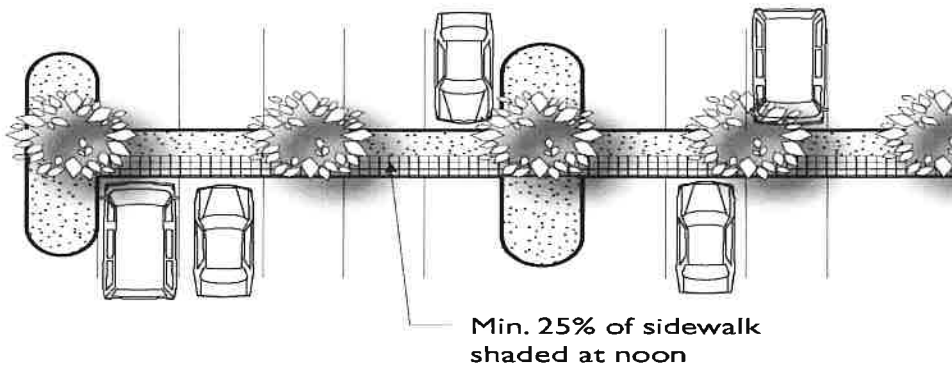

Figure 18.90.050.C.3. Medians with Sidewalks

D. Plant Materials.

1. Number of Plants.

a. *Parking Lot Landscape Islands.* One shade tree and three shrubs shall be provided for every 15-foot parking island.

b. *Parking Lot Divider Medians.* In addition to the above requirements, a minimum of one shade tree and six shrubs shall be provided for every eight parking spaces.

2. *Size of Plants.* A minimum 60 percent of the required trees shall be at least 24-inch box, and the remaining can be a minimum of 15-gallon box. Substitution based on plant size is not permissible for trees planted within the interior of a parking lot.

3. *Ground Cover.* All landscape planting areas that are not dedicated to trees or shrubs shall be permeable. No hardscape materials are permitted in designated planting areas.

[Res. 21-09; Ord. 21-05 § 2; Res. 14-36 § 404.05; Ord. 14-12 § 1.]

18.90.060 Recreation and Tot Lot Design Requirements.

1. All tot lots incorporated into open space must be covered with a shade structure over the play equipment. All tot lots and play structures shall be designed to be located at least one foot above the 100-year, two-hour storm level if located within a retention or detention area.

2. Recreational courts and fields to facilitate basketball, soccer, volleyball and other sports shall be designed to be located at least one foot above the 50-year storm level if located within a retention or detention area.
 3. Tot lot playground surfaces must consist of a rubberized material, commonly referred to as “tot turf,” or other resilient surface, in the designated fall zones as designated in or by the playground equipment manufacturer’s specifications.
 4. Sand shall not be a permitted material for use within the tot lot area.
 5. All grass installed in a development for general landscape use and for open space must be hypo-allergenic (midiron) sod or stolon. Seed can be utilized if grass is established prior to certificate of occupancy (C of O).
 6. Outdoor lighting, in conformance with the standards outlined in Chapter 18.95 MCC, shall be required at both the tot lot and the ramada area, as approved by the zoning administrator.
 7. A ramada provided within the open space areas must be constructed with stone columns or other durable material of equal quality, as approved by the zoning administrator, and a solid roof structure, such as but not limited to, standing seam metal, corrugated metal, concrete tile, clay tile or similar roof material. If associated with a recreational feature or a tot lot, the ramada must also include a BBQ grill, a minimum of two tables, two trash cans, and one bike rack.
 8. The location of neighborhood parks, mini parks, tot lots and similar recreation areas should wherever possible be internalized to the neighborhood and not adjacent to an arterial street or a body of water. If, however, a tot lot is placed adjacent to an arterial street or a body of water, it must be buffered with a wall constructed of stone or other durable material of equal quality, as approved by the zoning administrator, that is set back at least 10 feet from the sidewalk and 20 feet from a body of water.
 9. Recreational features can include elements such as, but not limited to: basketball, baseball, bocce ball, pickle ball, soccer, badminton, tennis, and fitness stations. Each element is designed for inclusivity and participation from residents of all ages.
 10. Restroom facility shall be required if a neighborhood park of five acres or more has two recreational activities (i.e., basketball court, soccer field, etc.), unless associated with a community center or school.
-

18.90.070 Alternative compliance.

An applicant who can demonstrate that the intent of this chapter can be exceeded, in whole or in part, may submit an alternative landscape plan (ALP) prepared in accordance with this section. The ALP shall include a narrative that clearly details the modifications being requested and explains how they enhance the landscape design principles listed below.

A. *Required Elements.* In order to qualify for consideration, an ALP shall demonstrate compliance with the following:

1. *Use of Drought-Tolerant or Native Vegetation.* Preservation or incorporation of drought-tolerant or native vegetation.
2. *Compatibility with Surrounding Uses and Desert Environment.* A greater degree of compatibility with surrounding uses and the desert environment than a standard landscape plan would offer. The number of shrubs and trees proposed depends on the type of shrub or tree planted and size at full maturity.
3. *Water Efficiency.* Use of water-efficient irrigation systems and xeriscaping at appropriate locations is essential.

B. *Approval and Required Findings.* ALPs may be submitted in conjunction with any development application, including PAD plans. An ALP may be approved by the reviewing body upon finding that:

1. There are unique characteristics of the property, site design, storm water management, or use that warrant special consideration to modify or deviate from the requirements of this chapter and that these characteristics are not self-created.
 2. The ALP meets or exceeds the minimum standards for plant materials of this chapter, while recognizing the unusual site design or use restraints on the property and specific characteristics of the landscape design justify declaration from specific members or pre-approved plans established for standard landscape plans.
 3. Approval of an ALP will provide for both increased consistency and compatibility with adjacent properties and the natural desert environment.
 4. The ALP demonstrates innovative use of plants and efficient use of water. [Res. 21-09; Ord. 21-05 § 2; Res. 14-36 § 404.06; Ord. 14-12 § 1.]
-

18.120.240 Group home.

Group homes are permitted in all single-family districts subject to the requirements provided herein. The purpose of these regulations is to permit minors, disabled, handicapped or elderly persons to reside together in single-family residential neighborhoods in compliance with the Fair Housing Act, while preserving the residential character of the neighborhood.

A. *Registration.* Group homes with seven to 10 residents shall submit a completed zoning permit application and required supplemental materials to the planning division on a form established by the zoning administrator. For group homes with seven to 10 residents that are licensed by the state, county or other governmental authority, a tentative zoning permit may be issued upon verifying the application complies with the standards below. Said group homes shall be considered to be registered with the city at the time they receive a tentative zoning permit. In all cases, permits for group homes shall terminate when the group home use ceases.

B. *Standards.* Group homes shall be located, developed, and operated in compliance with the following standards:

1. *Occupancy.* The number of residents, excluding staff, shall not exceed:
 - a. One to six residents: No zoning permit required.
 - b. Seven to 10 residents: A zoning permit is required.
 2. *Separation.* The minimum separation between group homes containing seven to ten residents shall be 1,200 feet, as measured from the closest property lines. There is no separation requirement for group homes containing one to six residents.
 3. *Exterior Appearance.* There shall be no sign or other exterior indication of a group home visible from a street. A minimum six-foot-high wall or fence shall be provided for purposes of screening and securing outdoor recreational areas.
 4. *Compliance with All Applicable Building and Fire Safety Regulations.* Group homes shall comply with any and all other applicable state or local requirements including, but not limited to, the city's building and fire codes. These requirements may require safety measures such as fire sprinklers, alarms and monitoring systems depending on such factors as the number of residents and whether the residents are capable of self-preservation.
-

5. *Licensing.* Group homes shall comply with any and all applicable state licensing requirements.
6. *Parking.* Any parking for the group or residential care homes shall be on site and comply with the requirements of Chapter 18.105 MCC, On-Site Parking and Loading.
7. *Exclusive Use.* All administrative activities, including staffing, counseling, and other visitations, shall serve only the residents of the group home.
8. *Preemptions.* Notwithstanding the foregoing, if the state has adopted laws or rules for the regulation of a specific type of group home, then any such state law or rule shall apply in addition to the conditions listed herein and/or shall preempt any conflicting condition listed herein.

C. *Request for Accommodation.* If a group home owner believes any requirement of the zoning code prevents the establishment of a group home in an economically viable manner, the owner shall submit to the zoning administrator a written request for accommodation and the reasons why the accommodation is required. The written request shall contain sufficient facts to allow the zoning administrator to make an individualized determination of the group home's needs, to address the city's safety and welfare concerns, and to assure compliance with this section. The zoning administrator shall review the written request and determine:

1. Whether an accommodation should be made pursuant to the requirements of the Fair Housing Act;
 2. If so, the nature of the accommodation taking into consideration the requirements of the Fair Housing Act, public safety and welfare concerns, and the residential character of the neighborhood; and
 3. The accommodation shall be made only to the extent necessary to comply with the Fair Housing Act. Profitability or financial hardship of the owner/service provider of a facility shall not be considered by the zoning administrator in determining to grant a reasonable accommodation waiver. An appeal of the decision of the zoning administrator may be made regarding reasonable accommodation to the hearing officer pursuant to Chapter
-

18.120.260 Temporary uses.

Temporary uses require an approved temporary use permit to operate pursuant to MCC [18.150.080](#) unless otherwise specified in this code. Temporary uses shall be located, developed, and operated in compliance with the following standards:

A. *General.* A temporary use is intended to operate only for a limited period of time.

B. *Carnivals, Fairs, and Festival Events.* Carnivals, fairs, and festival events, including arts and neighborhood and community fairs, in connection with an existing commercial use or in conjunction with an activity of a civic organization, church, lodge, public or private educational facility, or other such group or organization are permitted in accordance with the following standards:

1. *Location.* Carnivals, fairs, and festival events are limited to areas within commercial, mixed use, and employment districts, or on property owned by a public or private educational facility, institution, or religious facility. Corn mazes and similar activities are permitted in rural districts. Neighborhood and community fairs are permitted in rural and residential districts.
2. *Time Limit.* When located within or adjacent to a residential district, the hours of operation shall be limited to 8:00 a.m. to 9:00 p.m., unless a longer time period is approved with a temporary use permit.
3. *Duration.* Carnivals, fairs, revivals and festival events are limited to no more than 10 consecutive days, separated by at least 30 calendar days four times a year. A more limited duration may be established in order to prevent the use from becoming a nuisance with regard to the surrounding neighborhood or the city as a whole.
4. *Existing Parking.* Where such a use is proposed within a developed parking lot, the available parking shall not be reduced to less than 75 percent of the minimum number of spaces required by this code (or an alternative method for parking is approved by staff), and traffic access shall be maintained.

C. *Farmers Markets.* Farmers markets shall be located, developed, and operated consistent with the following standards:

1. *Operator.* Farmers markets must be operated by one or more certified producers, a nonprofit organization, or a local government agency.
 2. *Vendors.* At least 70 percent of vendors must be farmers, ranchers, and other businesses who sell food, plants, flowers, and added-value products such as jams and jellies.
 3. *Management Plan.* A management plan shall be prepared and provided to the zoning administrator. The management plan shall include the following:
 - a. Identification of a market manager or managers, who shall be present during all hours of operation.
 - b. A set of operating rules addressing the governance structure of the market, the method of assigning booths and registering vendors, hours of operation, maintenance, security, refuse collection, and parking.
 4. *Hours of Operation.* Market activities shall be conducted between the hours of 7:00 a.m. and 7:00 p.m. Setup of market operations shall begin no earlier than 6:00 a.m., and takedown shall end no later than 8:00 p.m.
 5. *Waste Disposal.* Adequate composting, recycling, and trash containers shall be provided during hours of operation, and shall be removed from the site for appropriate disposal. The site shall be cleaned at the end of each day of operations, including the removal of all stalls and debris.
- D. *Garage Sales.* A garage or yard sale may be conducted on any developed lot in a residential or rural district, subject to the following requirements. No permit is necessary to conduct a garage sale.
1. No more than four such sales may be conducted on any one lot in any one calendar year.
 2. Each sale period shall be for no more than three days within a three-month duration.
 3. All merchandise to be sold shall be displayed on a private lot and not within the public right-of-way. Merchandise shall be personal property of the family or families hosting the sale and shall not have been purchased for resale.
-

E. *Model Homes*. Model homes with sales offices and temporary information/sales trailers in new residential subdivisions are subject to the following requirements:

1. *Time Limits*. A temporary information/sales trailer may be used during the construction of the model homes for a maximum period of 12 months.
2. *Location of Sales*. Real estate sales conducted from a temporary sales office are limited to sales of lots within the subdivision it is located in and to other subdivision projects under the same ownership.
3. *Return to Residential Use*. Prior to the close of a sale of any of the model homes as a single-family residence, any portion used for commercial purposes will be converted to its intended residential purpose, including flagpoles.
4. *Term of Use*. The model home may be established and operated until completion of the sale of the lots or residences within the subdivision, or for a duration specified as a condition of the temporary use permit.

F. *Swap Meets*. Outdoor swap meets, antique markets, and similar multi-vendor open-air ventures are allowed in accordance with the following standards:

1. *Location*. Outdoor markets are limited to areas within public/semi-public, commercial, mixed use, and employment districts, or on property owned by a public or private educational facility, institution, or religious facility.
2. *Time Limit*. When located within or adjacent to a residential district, the hours of operation shall be limited to 8:00 a.m. to 9:00 p.m., unless a longer time period is approved with a temporary use permit.
3. *Duration*. Swap meets may only operate once per month for no more than two consecutive days.
4. *Existing Parking*. Where such a use is proposed within a developed parking lot, the available parking shall not be reduced to less than 75 percent of the minimum number of spaces required by this code (unless an alternative method for parking is approved by city staff), and traffic access shall be maintained.

G. *Temporary and Seasonal Outdoor Sales*. Temporary and seasonal outdoor sales are allowed in accordance with the following standards.

1. *General Requirements.* Temporary outdoor sales, including but not limited to grand opening events, and other special sales events, on private property in nonresidential districts are subject to the following standards:
 - a. Except for seasonal sales, temporary outdoor sales are part of an existing business on the same site and are limited to a seven-day period four times a year.
 - b. Sales events must be conducted solely on private property and not encroach within the public right-of-way or occupy required parking, unless an alternative parking scenario is approved by staff to meet the intent. Location of the displayed merchandise must not disrupt the normal circulation of the site, nor encroach upon driveways, pedestrian walkways, or required landscaped areas, or obstruct sight distances or otherwise create hazards for vehicle or pedestrian traffic.
 - c. Approval of a Zoning Permit by the City of Maricopa is required prior to commencement of the proposed event.

 2. *Seasonal Sales.* The annual sales of Christmas trees, fireworks, pumpkins and similar events, as determined by the Zoning Administrator, permitted in accordance with the following standards:
 - a. *Time Period.* Pumpkin sales are permitted from October 1st through November 7th. Christmas tree sales are permitted from November 15th through December 31st. Seasonal sales associated with other holidays are permitted up to a month preceding and one week following the holiday.
 - b. *Signs.* A maximum of two (2) banners (40sf each), one (1) A-Frame (6sf), and one (1) Flying Banner (12sf) are permitted for each seasonal sales location. Additional sign criteria can be found listed in Section 18.115.120 of the Maricopa Municipal Code. No additional sign permit submittals will be required.
 - c. *Goods, Signs and Temporary Structures.* All trees, pumpkins, or other items for sale, as well as signs and temporary structures, shall be removed within five days after the end of sales, and the appearance of the site shall be returned to its original state.

 3. *Nonprofit Fundraising.* Fundraising sales by a nonprofit organization for up to three days per event.
-

4. *Long-Term Special Events and Sales.* Other special events, outdoor sales, and displays that exceed seven consecutive days may be permitted in accordance with the following standards:

- a. *Location.* Events are limited to nonresidential districts.
- b. *Number and Duration of Events.* No more than four events at one address shall be allowed within any 12-month period unless a temporary use permit is obtained. The duration of any single event shall not exceed 30 days.
- c. *Existing Business.* Temporary outdoor sales shall be part of an existing business on the same site.
- d. *Signs.* Signs shall conform with the provisions of Chapter 18.115 MCC.

5. *Vehicle Sales Prohibited.* The parking of privately owned used automobiles in parking lots for the express purpose of offering the vehicle for sale is prohibited, unless permission is granted by the property owner and multiple cars are not offered for sale at one time. This restriction does not apply to automobile/vehicle sales and leasing uses. [Res. 21-09; Ord. 21-05 § 2; Res. 14-36 § 410.26; Ord. 14-12 § 1.]

Chapter 18.120

STANDARDS FOR SPECIFIC USES

- 18.120.010 *Accessory uses.*
 - 18.120.020 *Adult-oriented businesses.*
 - 18.120.030 *Alcoholic beverage sales.*
 - 18.120.040 *Automobile/vehicle sales and leasing.*
 - 18.120.050 *Automobile/vehicle service and repair, major.*
 - 18.120.060 *Automobile/vehicle service stations and washing.*
 - 18.120.070 *Community assembly.*
 - 18.120.080 *Day care facilities.*
 - 18.120.090 *Drive-in and drive-through facilities, including fast-food facilities.*
 - 18.120.100 *Eating and drinking uses.*
 - 18.120.110 *Repealed.*
 - 18.120.120 *Home occupations.*
 - 18.120.130 *Hospitals and clinics.*
-

- 18.120.140 Live/work units.
- 18.120.150 Manufactured home/recreational vehicle uses.
- 18.120.160 Qualifying marijuana facilities.
- 18.120.170 Mobile merchants.
- 18.120.180 Off-track betting establishments.
- 18.120.190 Outdoor dining and seating.
- 18.120.200 Noninstitutional banking.
- 18.120.210 Personal services and restricted personal services.
- 18.120.220 Personal storage facilities.
- 18.120.230 Recycling facilities.
- 18.120.240 Group home.
- 18.120.250 Restricted retail uses.
- 18.120.260 Temporary uses.
- 18.120.270 Transitional and supportive housing facilities.
- 18.120.280 Food and beverage sales.
- 18.120.290 Charitable donation containers.

- 18.120.300 **Food Truck Courts**

18.120.300 Food Truck Courts.

A. Specific Standards:

1. All Food Truck Courts sites must be reviewed, permitted, and developed in accordance with the Maricopa City Code and the adopted Building Code, including those for signage and waste collection, and shall comply with the following standards.
 - a. On-site management is required to be present during all hours of operation to ensure compliance with the required standards.
 - b. Hours of operation are limited to 7:00 a.m. to 10:00 p.m.
 - c. Canopies, awnings, or shade structures designed to shield operators or patrons must meet the Maricopa City Code and adopted Building Code requirements and must be permanently affixed to the ground.
 - d. If all, or part, of the Food Truck Courts operate outdoors, those outdoor portions shall also comply with the following standards, including outdoor lighting requirements.
-

- i. All vendors shall be located within a developed stall. The number of vendors will be limited by the number of developed stalls. A developed stall shall be graded and compacted with a dust proof surface, meet ADA-compliant access, and separation requirements for fire clearance.
 - ii. Overnight parking for vendors is not allowed.
 - iii. Permanent power pedestals for each vendor stall are required.
 - iv. Temporary or permanent accessible restrooms and a parking area with delineated parking spaces with a dust-proof surface may be permitted as exceptions to the standard requirements if requested in the development submittal package.
 - v. If located within an existing developed site, such as a shopping center parking area, excess available parking may be allocated to the requirements for the Food Truck Court. Parking spaces utilized for vendor parking and patron access may continue to be counted towards the parking provided onsite. Onsite circulation standards and fire routes must be maintained. Additional landscaping standards as defined in Chapter 18.90 MCC and stormwater retention and detention standards (DSM Part 3) are not required.
 - vi. If located within an undeveloped site and permanent paving is not provided, regulations of dust-controlled surfaces, lighting, and vehicular ingress and egress and traffic circulation are required. Landscaping standards as defined in Chapter 18.90 of the Maricopa Zoning Ordinance and stormwater retention and detention standards (DSM Part 3) do not apply.
- B. Signage: Food Truck Courts shall follow the general criteria for Temporary Signs as defined in Chapter 18.115.120.C MCC.
- C. Permit Type: Food Truck Courts are allowed under a Temporary Use Permit as defined in Chapter 18.150.080 MCC.
- D. It will be the responsibility of the vendor to obtain all necessary inspections and permits or licenses as required by state statutes, including Pinal County Division of Environmental Health, and any other applicable agencies or entities.
- E. The zoning administrator may evaluate and accept an alternative method/design that meets the intent and spirit of the code and other City of Maricopa policy documents.
-

18.135.020 City council.

A. *Duties and Powers Related to Zoning.* The city council shall have the duty to carry out the provisions and intent of the general plan and this code. Specifically, the city council has the powers to do the following:

1. *Appointment Powers.* The city council shall have the power to appoint and remove members of the planning and zoning commission and the hearing officer.
2. *Initiation Powers.* The city council or planning and zoning commission shall have the power to initiate legislation and hold public meetings and public hearings on the following:
 - a. General plan amendments;
 - b. Zoning code map or text amendments. The city council shall have the power to initiate applications with or without owner authorizations for either zoning code map or text amendments as provided by state law; and
 - c. Area specific plans.
3. *Decision-Making Powers.* The city council shall have the power to make final decisions and hold public meetings and public hearings to review and approve, continue, deny, or approve with conditions the following requests:
 - a. General plan amendments;
 - b. Zoning code text and zoning map amendments;
 - c. Planned area development (PAD) districts and PAD plans in PAD zoning districts, and major amendments or major modifications to conditions of approved planned area development districts and plans, as defined in this code;
 - d. Area specific plans; and
 - e. Annexations.
4. *Appeal Powers.* Refer to Table 18.140.140.

B. The city council may prescribe, in connection with a decision noted in subsections (A)(3)(c) and (A)(3)(d) of this section, conditions of approval as the council deems necessary, in order to

fully carry out the provisions and intent of the general plan and this code, pursuant to MCC 18.140.100, Conditions of approval. Violations of any city council condition of approval shall be a violation of this code.

C. *Appeals*. Any person aggrieved by a decision of the city council under this code may file an appeal to the Pinal County superior court within 30 calendar days after the city council has rendered its final decision, in accordance with MCC 18.140.140, Appeals.

18.135.030 Planning and zoning commission.

A. *Creation and Purpose*. The planning and zoning commission is created to hold public meetings and hearings, to provide analysis and recommendations to the city council regarding general land use policies where the commission has such advisory responsibility, and to render decisions where the commission has been assigned decision-making power by this code. The purpose of the planning and zoning commission is to support creation of a desirable environment throughout the city for residents, business, and industry in areas for which it is responsible by promoting harmonious, safe, attractive, and compatible development that is in the best interest of public health, safety, and general welfare.

B. *Duties and Powers*. The planning and zoning commission shall have the duty to carry out the duties outlined in Chapter 2.15 MCC.

1. *Decision-Making Responsibilities*. The planning and zoning commission shall have the power to hold public meetings and public hearings to review and approve, continue, deny, or approve with conditions:

a. Conditional use permits and modifications to such permits; and

2. *Advisory Responsibilities*. The planning and zoning commission shall hold public meetings and hearings to advise and recommend to the city council:

a. General plan amendments and major amendments;

b. Zoning map amendments (e.g., rezonings) for base and overlay zoning districts;

c. Zoning code text amendments;

d. *Repealed by Ord. Repealed.*

- e. PAD districts and PAD plans; and
 - f. Area specific plans.
3. The planning and zoning commission may recommend in connection with any application such conditions as the commission deems necessary in order to fully carry out the provisions and intent of this code.

C. *Organization.*

1. *Number of Members.* The commission shall have seven members, with each nominated by a member of the council.
 2. *Eligibility of Members.*
 - a. Members must be a current city of Maricopa resident, property owner or business owner for a minimum of one year.
 - b. Members must be at least 18 years of age and registered to vote in Pinal County.
 - c. Members appointed to the commission shall not be a direct family member (parent, spouse, sibling or child) of a sitting member of council unless there are not sufficient applicants for the position.
 3. *Term of Members.*
 - a. A member's tenure shall be coterminous with the term of office of the nominating member of council.
 - b. Members shall continue to serve until their successor is approved by a vote of council.
 - c. In the event of death, resignation, or removal of a member, a vacancy will be declared and the nominating member of council shall be informed of the vacancy and allowed to begin the selection process for a new member.
 4. *Resignations or Removal of Members.*
 - a. Members will notify the nominating member of council of their intent to resign their appointment prior to the end of their term.
-

- b. Any member may be removed by a majority vote of council.
- c. Any member who is absent for three consecutive meetings or is absent from any four meetings over a six-month period, without contacting the chairperson, shall be considered as having resigned his/her position.

5. Hearings of the planning and zoning commission shall be scheduled at a time and place as declared by the planning and zoning commission. Special meetings of the commission may be called by the chairperson, or by any three members of the planning and zoning commission. Meetings shall be open to the public, with only such exceptions as may be permitted by state law with respect to executive session, and public input shall be permitted in all public meetings on matters before the commission. The public shall be given an opportunity to testify orally or in writing. The minutes of its proceedings showing the vote of the body, records of the commission's deliberations, and other official actions shall be kept by the city clerk as a public record.

6. The planning and zoning commission shall adopt rules of procedure consistent with the provisions of the city code for the conduct of its business and procedure.

7. A quorum consists of four members of the planning and zoning commission. The concurring vote of the majority of the quorum of the planning and zoning commission shall be necessary to act on any matter on its agenda. In the event that planning and zoning commission members are not sufficiently available to make a quorum, there shall be no meeting. Robert's Rules of Order shall govern any other motion.

8. The development services director, or a designated representative, shall serve ex officio as secretary of the planning and zoning commission.

D. *Appeals.* Planning and zoning commission recommendations to the city council are not final decisions. Any person aggrieved by a final decision of the planning and zoning commission may file an appeal to the city council in accordance with MCC 18.140.140.

18.135.050 Development services director.

A. *Creation and Purpose.* The director of the development services department (the "director"), or his designee, directs the work of the department and the planning and zoning division and leads the department in fulfilling its mission.

B. Duties and Powers.

1. The development services director shall have the duty to carry out the provisions and intent of the general plan and this code. The development services director, or designee, shall have the power to do the following:

- a. Serve as staff of the planning and zoning commission and the hearing officer;
- b. Issue administrative regulations for the submission and review of applications subject to the requirements of this code and A.R.S. § 9-831 et seq.;

C. Authorized to receive, process and approve applications for final subdivision plats, in accordance with this Ordinance.

d. Process and make recommendations to the planning and zoning commission and the city council on all applications, amendments, appeals and other matters upon which the council has the authority and the duty to act under this code;

e. Investigate and make reports to the planning and zoning commission on violations of permit terms and conditions when the city has initiated revocation procedures;

f. Appoint and oversee the hearing officer and zoning administrator; and

g. Delegate administrative and enforcement functions as they so deem to members of the development services department staff.

18.135.060 Hearing officer.

A. *Creation and Purpose.* The hearing officer is created to hold public hearings to provide relief from the terms of this code by variance applications and to hear and decide appeals from decisions of the zoning administrator.

B. *Duties and Powers.* The hearing officer shall have the duty to carry out the provisions outlined in Chapter 2.15 MCC and this code.

1. The hearing officer shall hold a public hearing or public meeting to review and approve, continue, deny, approve with conditions, or to the extent applicable, enter the appropriate order, the following:

- a. Appeals from decisions made by the zoning administrator or designee, regarding the following:
 - i. Waivers;
 - ii. Temporary use permits;
 - iii. Modifications to waivers and temporary use permits;
 - iv. Zoning permits;
 - v. Development review permits;
 - vi. Preliminary Plats;
 - vii. Final Plats;
 - viii. Modifications to approved zoning permits, development review permits, and zoning permits; and
 - ix. Any other decision made by the zoning administrator or designee.
 2. The hearing officer shall not:
 - a. Make any changes in the uses permitted in any zoning classification or zoning district, or make any changes in the terms of the zoning code, provided the restriction in this subsection shall not affect the authority to grant variances pursuant to this code; or
 - b. Grant a variance if the special circumstances applicable to the property are self-imposed by the property owner.
 3. The hearing officer may, in connection with any application, impose conditions as the hearing officer deems necessary in order to fully carry out the provisions and intent of this code. Violation of any hearing officer condition shall be a violation of this code.
 4. Authorize a reduction of the off-street parking and loading requirements of this code, if it should find that in the particular case the peculiar nature of the building or premises, or an exceptional situation or condition, would mitigate the need for the parking spaces specified. The hearing officer shall consider such requests only after the remedies available in this code have been exhausted.
-

C. *Organization.*

1. The provisions of Chapter 2.15 MCC shall apply for the composition, number, and qualifications of the hearing officer.
2. Hearing officer meetings shall be open to the public. The public shall be given an opportunity to testify orally or in writing. The minutes of its proceedings, records of the hearing officer discussion and other official actions shall be kept by the city clerk as a public record.
3. The hearing officer shall adopt rules of procedure consistent with the provisions of the city code for the conduct of its business and procedure.
4. The development services director, or a designated representative, shall serve ex officio as the secretary of the hearing officer.

D. *Appeals.* Refer to MCC 18.140.140. [Res. 23-19; Ord. 23-17 § 2.]

Disclaimer: The city clerk's office has the official version of the Maricopa City Code. Users should contact the city clerk's office for ordinances passed subsequent to the ordinance cited above.

18.135.070 Zoning administrator.

A. *Creation and Purpose.* The zoning administrator is appointed by the development services director. The zoning administrator is created to interpret the meaning and intent of the general plan and this code and enforce the provisions contained therein.

B. *Duties and Powers.*

1. The zoning administrator shall have the duty to carry out the provisions and intent of the general plan and this code. The zoning administrator shall have the power to hold a public hearing to review and approve, continue, deny, or approve with conditions the following:
 - a. Zoning permits;
 - b. Minor development review permits;
 - c. Temporary use permits;
-

- d. Waivers;
 - e. Preliminary Plats;
 - f. Minor modifications to waivers and temporary use permits;
 - g. Modification to zoning permits, temporary use permits and minor development review permits;
2. The zoning administrator shall interpret the code as needed. Interpretation of this code includes, but is not limited to, clarification of intention, determination of zoning classifications of land uses not specified in this code, and the delegation of processing procedures and requirements. The zoning administrator shall keep a record of interpretations made pursuant to this section. The record of interpretations shall be available to the public;
3. The zoning administrator shall serve on the technical advisory committee and advise on matters relating to development and subdivision plat applications;
4. The zoning administrator may carry out any functions and duties specified in this code; and
5. The zoning administrator shall delegate administrative functions as deemed necessary to execute the intent of this code to members of the development services department staff.

C. *Appeals.* Any person aggrieved by a decision of the zoning administrator under this code may file an appeal to the hearing officer in accordance with MCC [18.140.140](#), Appeals. Decisions shall be heard de novo by the hearing officer as applicable.

18.135.110 Summary of review authorities for permit types.

Table 18.135.110 summarizes review authorities for each permit type, including the advisory body, the decision-maker, and the appeal body. Decisions of the hearing officer are final, and the only appeal is to the city council.

Table 18.135.110 Review Authorities

Application or Action	Chapter	Advisory Body	Decision Maker	Appeal Body
Zoning Permit	<u>18.145</u>	n/a	Zoning Administrator	Hearing Officer*
Conditional Use Permit	<u>18.150</u>	Zoning Administrator	Planning and Zoning Commission	City Council
Temporary Use Permit	<u>18.150</u>	Zoning Administrator	Zoning Administrator	Hearing Officer
Development Review Permit Major (5,000 square feet and above) Minor	<u>18.155</u>	Major: Zoning Administrator Minor: n/a	Major: Zoning Administrator Minor: Zoning Administrator	Major: City Council Minor: Hearing Officer
Changes to an Approved Development Review Permit	<u>18.155</u>	Major(1): Zoning Administrator Minor(1): n/a	Major(1): Zoning Administrator Minor(1): Zoning Administrator	Major(1): Hearing Officer Minor(1): Hearing Officer
Waiver from Dimensional Standards	<u>18.165</u>	N/A	Zoning Administrator	Hearing Officer

Application or Action	Chapter	Advisory Body	Decision Maker	Appeal Body
Variances	<u>18.160</u>	Zoning Administrator	Hearing Officer	City Council
Permit Revocation	<u>18.140.130</u>	Zoning Administrator	Original decision-making body	Original decision-making body
General Plan Text and Map Amendments	<u>18.170</u>	Planning and Zoning Commission	City Council	Superior Court
Zoning Code and Map Amendments	<u>18.175</u>	Planning and Zoning Commission	City Council	Superior Court
Planned Area Development Districts	<u>18.180</u>	Planning and Zoning Commission	City Council	Superior Court
Final Subdivision Plats	<u>17.20.060</u>	N/A	Development Services Director and City Engineer	Hearing Officer
Preliminary Subdivision Plat	<u>17.20.050</u>	N/A	Zoning Administrator	Hearing Officer

¹ Refer to MCC 18.155.040 for definition of a minor development review permit and MCC 18.155.050 for definition of a major development review permit.

* Note that any decision by the hearing officer is appealed to the superior court.

18.140.050 Neighborhood meetings and notifications.

A. *Purpose.* The purpose of a neighborhood meeting is to provide a means for the applicant, surrounding residential neighbors, and registered neighborhood and homeowners association representatives to review a preliminary project and solicit input and exchange information about the proposed project prior to public hearings. Spanish-speaking and ASL interpreters shall be provided at the neighborhood meeting, if requested prior to the meeting scheduled. This preliminary meeting is intended to result in an application that is responsive to neighborhood concerns and to expedite and lessen the expense of the review process by avoiding needless delays, appeals, remands or denials. The applicant is responsible for all costs associated with the neighborhood meeting.

B. *Applicability.* A neighborhood meeting is required for the following types of applications:

1. Conditional use permits;
2. Variances;
3. Planned area development;
4. Major modification to an approved plan or condition of approval (when original approval requires neighborhood meeting);
5. Annexation requests;
6. Zoning map amendments; and
7. General plan map amendments.

C. *Meeting Schedule.* The applicant is required to hold one meeting prior to the first public hearing on an application for a specific site, but may hold more if desired. The required meeting shall be held at least 15 days and not more than 90 days before the first public hearing on the application. Meetings held more than 90 days before the first public hearing shall be required to hold an additional neighborhood meeting. Neighborhood meetings shall not occur until after any required preliminary review meeting and consultation with the planning division staff.

D. *Meeting Location.* Neighborhood meetings shall be held at a location near the proposed development site. The meeting shall be held on a weekday evening or weekends at any reasonable time and in a publicly accessible location.

E. *Application Submittal.*

1. The neighborhood notice and meeting materials must be submitted with the project application(s) to the development services department, unless otherwise deferred by the zoning administrator to a later date. At a minimum, the following materials must be submitted:

- a. A narrative discussing the proposed time, place and location within the city of the neighborhood meeting;
- b. A list of names and addresses, labeled, stamped envelopes of all the property owners within the target area, and a notarized affidavit by the applicant that the list of names and addresses is accurate, current and complete;
- c. A list of names and addresses of all other interested parties who have requested that they be placed on a notification list maintained by the city clerk;
- d. A notification letter written in both English and Spanish, including a general explanation of the substance of the proposed application; the date, time and place within the city scheduled for a neighborhood meeting and for all other city meetings; and the city and applicant contacts;
- e. An eight-and-one-half-inch by 11-inch reduction of the proposed neighborhood sign; and
- f. The applicant's schedule for completion of the neighborhood meeting.

2. The zoning administrator or their designee shall be responsible (a) to review and approve all notification materials, neighborhood meeting location, a brief description of the property change and a land map; (b) to notify the applicant to proceed with the neighborhood meeting; and (c) for mailing the property owner notifications provided by the applicant.

F. *Notification Requirements.* Notice of the neighborhood meeting shall be provided at least 15 calendar days prior to the neighborhood meeting by the applicant in the following manner:

1. *Mailed Notice.* Written notice shall be mailed to all owners and occupants within 600 feet of the subject property, or a larger area as determined by the zoning administrator, and to
-

such other persons as the economic and community development department, or authorized designee, determines to be other potentially affected citizens.

2. *Posted Notice.* Notice shall be provided on the proposed site. The sign shall be waterproof and have a minimum size of 24 inches by 36 inches for all variances, temporary use permits and conditional use permits and a four-foot by eight-foot sign for all general plan amendments, planned area developments, zoning map amendments, and development review permits. All information on the sign shall be evenly spaced and organized in a readable manner. The number of signs and the location of the sign shall be determined by the zoning administrator or authorized designee.

3. *Electronic Notice.* Where applicable and not in violation of state law, notice may be provided by electronic means such as emailed notice, posted notice on the city's website, or other means determined by the zoning administrator. This type of notice may be substituted for advertised notice. Any persons or organizations may request that electronic notice be substituted for mailed notice through a request to the zoning administrator. Electronic notice cannot be substituted for certain legislative actions, such as rezoning.

4. *Contents of Notices.* All notices shall contain information about the proposal, project description, time, date, location of neighborhood meeting and subsequent city meetings for review and approval (if available), the availability of Spanish-speaking and ASL interpreters upon request, the names and telephone numbers citizens may call with questions and issues, and applicant and city of Maricopa contacts, including name and telephone number.

18.140.060 Public hearing notification.

A. *Purpose.* This section is intended to provide the public information about upcoming public hearings on land use issues and to provide property owners and interested organizations that may be impacted by a project of a pending action on a land use application. Public hearings shall be preceded by public notice in accordance with this section and state law.

B. *Applicability.* Notice is required for all applications that require a public hearing before the city council, planning and zoning commission, board of adjustment, hearing officer, or zoning administrator.

1. When multiple applications are under review for the same project, the city may simultaneously issue notice for multiple applications. The requirement that provides for greater notice shall apply.
2. The zoning administrator may require additional notification if necessary to meet the requirements of this code and the A.R.S.

C. *Notification Requirements.* Notification shall be provided in the following manner:

1. *Mailed Notice.* The applicant shall mail notices provided by the applicant by first class mail, in both English and Spanish.

- a. Time period:

- i. Public hearings: Not less than 15 or more than 45 days before the date of the public hearing.

- b. Recipients:

- i. The applicant, the owner, and any occupant of the subject property; and
- ii. All property owners of record and tenants of property within a minimum 600-foot radius of the subject property.

- c. *Notification List.* The applicant shall provide a list of property owners and occupants within the prescribed area of notification and shall sign an affidavit verifying that the list has been prepared in accordance with the procedure outlined in this section.

- i. *Property Owner Notice.* The last known name and address of each property owner as contained in the records of the Pinal County Assessor shall be used;
 - ii. *Tenant Notice.* The address of the residential and commercial tenants shall be determined by visual site inspection or other reasonably accurate means;
 - iii. All neighborhood and community organizations that have previously filed a written request for notice of projects in the area where the site is located; and
 - iv. Any person or group who has filed a written request for notice regarding the specific application.
-

2. *Newspaper Notice.* The development services department shall review the notice prior to the applicant publishing in at least one newspaper of general circulation in the city.

a. Time period: At least 15 days before the date of the public hearing.

3. *Posted Notice.* Notice shall be provided on the proposed site. The sign shall be colored and waterproof and have a minimum size of 24 inches by 36 inches for all variances, temporary use permits, and conditional use permits and a four-foot by eight-foot sign for all general plan amendments, planned area developments, and zoning map amendments. All information on the sign shall be evenly spaced and organized in a readable manner. The sign shall include the proposal, project description, time, date, location of neighborhood meeting, the names and telephone numbers that citizens may call with complaints and applicant and city contacts, including name and telephone number. The number of signs and the location shall be determined by the zoning administrator or authorized designee.

a. Time period: At least 15 days before the date of the public hearing.

4. *General Plan and Zoning Code Amendments.* All notification procedures outlined in A.R.S. §§ 9-462.03 and 9-462.04 must be met. Any general plan or zoning code amendments must meet the following requirements:

a. *Newspaper Notice.* Notice shall be provided by a “display ad” covering not less than one-eighth of a full page in a newspaper of general circulation in the city (A.R.S. § 9-462.04(A)(5)).

b. *Posted Notice.* If there is no newspaper of general circulation published or circulated in the city, then notice shall be posted on the affected property and in at least 10 public places in the municipality. The posted notice shall be printed in such a manner so that the following are visible from a distance of 100 feet: the word “zoning,” the present zoning district classification, the proposed zoning district classification, and the date and time of the hearing (A.R.S. § 9-462.04(A)(1)).

5. *Electronic Notice.* Notice will be provided by electronic means such as emailed notice, posted notice on the city’s website and social media, or other means determined by the zoning administrator. This type of notice may be substituted for advertised notice. Any persons or organizations may request that electronic notice be substituted for mailed

notice through a request to the zoning administrator. Electronic notice shall not substitute for any notification required by state law.

18.205.020 List of definitions.

“Floor area” means the total floor area in a building (including basements, mezzanines, interior balconies, and upper stories or levels in a multistory building) unless otherwise stipulated, e.g., “ground floor” area.

“Floor area ratio” means the numerical value obtained through dividing the aboveground gross floor area of a building or buildings located on a lot or parcel of land by the total area of such lot or parcel of land.

“Food Truck Court” means a unified establishment that serves food for consumption on or off the premises from multiple eateries or vendors. Food Truck Courts may be developed to include any combination of indoor or outdoor operations. A commercial kitchen, exclusively for use by vendors on location at the Food Truck Court, is permitted provided it meets all applicable state and local health standards, as well as all relevant requirements of the Maricopa City Code.

“Forecourt” means a private frontage wherein a portion of the facade is close to the frontage line and the central portion is set back.

“Foster home” means a dwelling maintained by an individual or individuals having care or control of one but not more than six minor children, other than those related by blood, marriage, or adoption or those who are legal wards of such individuals, which is licensed by the Arizona State Department of Economic Security.

“Sight visibility triangle” means the area of visibility on a street corner to allow for safe operations of vehicles, pedestrians, and cyclists in the proximity of intersecting streets, rail lines, sidewalks, and bicycle paths.

“Single-family residential design guidelines” means the city of Maricopa single-family residential design guidelines adopted by the city council.

“Single household” means any number of related, or up to five unrelated, persons living as the functional equivalent of a traditional family, whose members are an interactive group of persons jointly occupying a single dwelling unit, including the joint use of and responsibility for

common area, and sharing household activities and responsibilities (e.g., meals, chores, household maintenance, expenses, etc.) and where, if the unit is rented, all adult residents have chosen to jointly occupy the entire premises of the dwelling unit, under a single written lease with joint use and responsibility for the premises of the dwelling unit rather than the landlord or property manager.

“Single-room Occupant (SRO)” means a type of housing where individuals rent a single room as their primary residence, typically sharing communal facilities like kitchens and bathrooms within a multi-tenant building.

“Site plan review” means a process exercised under the prior zoning code, which provided a review and approval procedure for all non single-family residential construction or development proposals.
